

DEWALT®

Fig. A

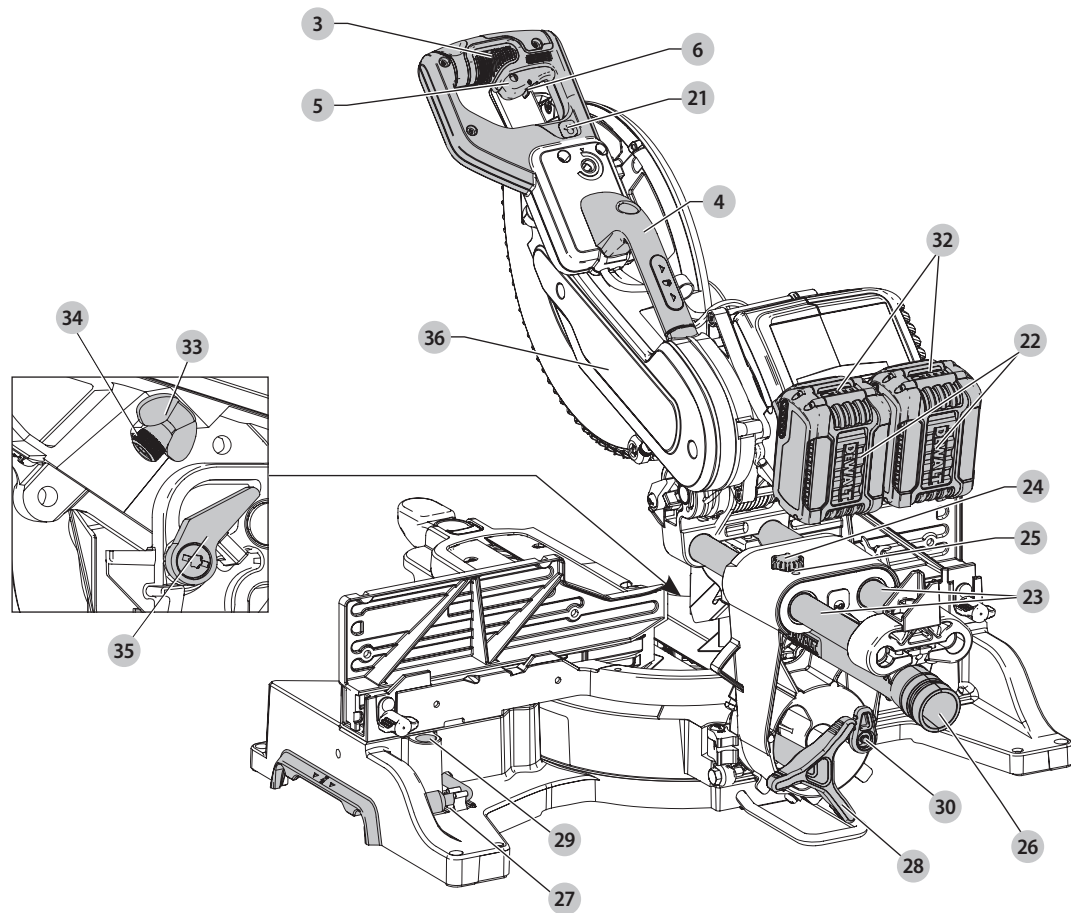
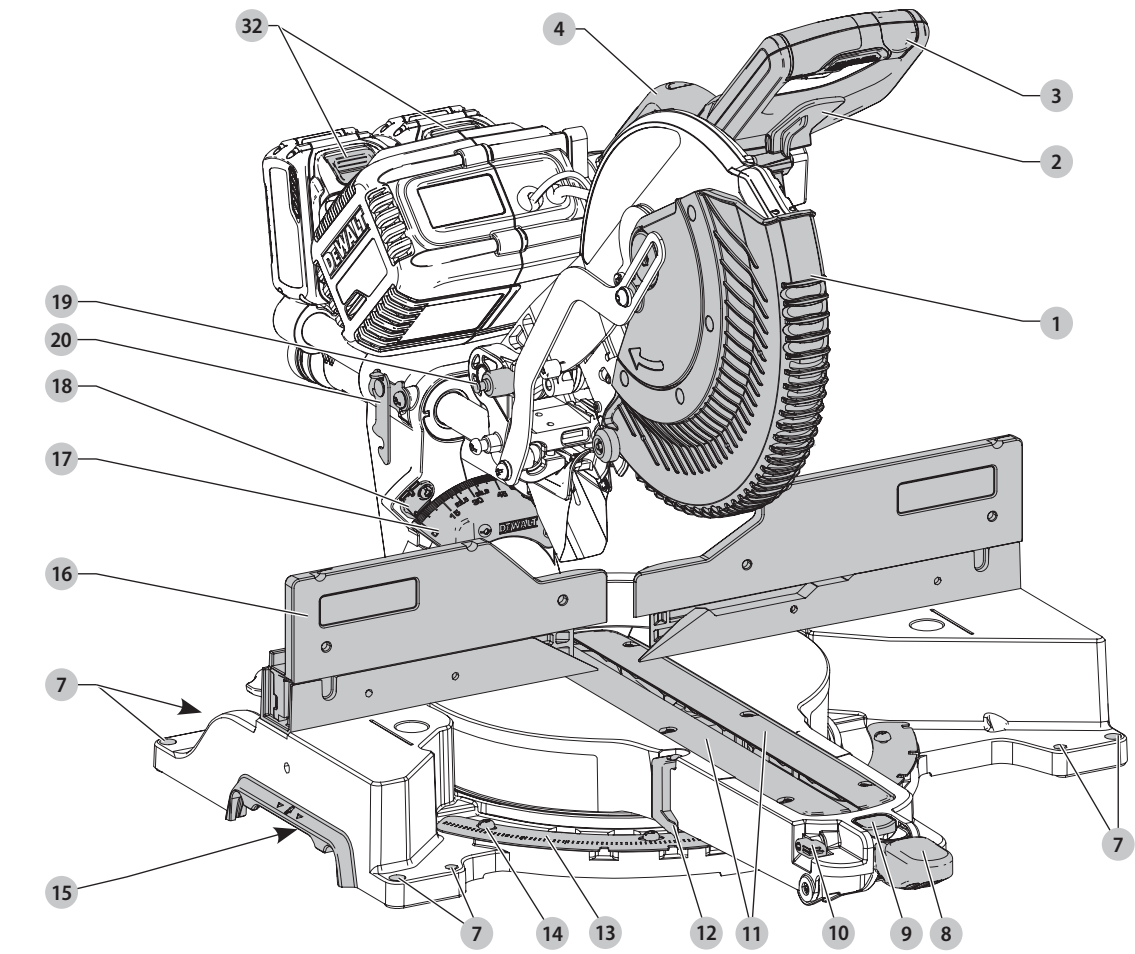

Fig. B

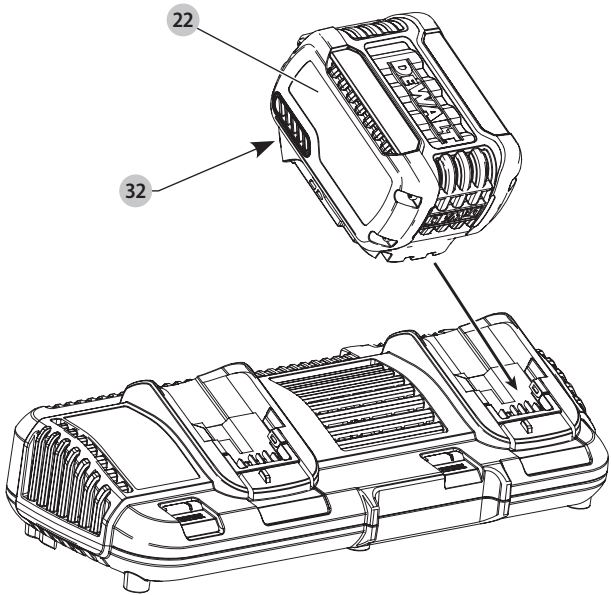

Fig. C1

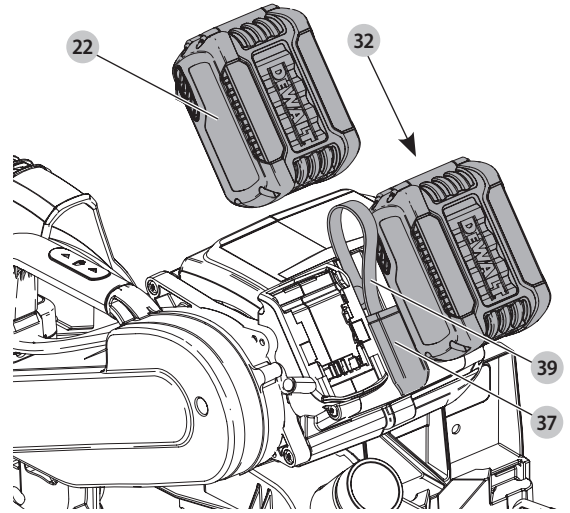

Fig. C2

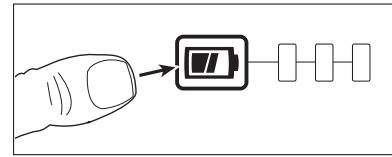

Fig. D

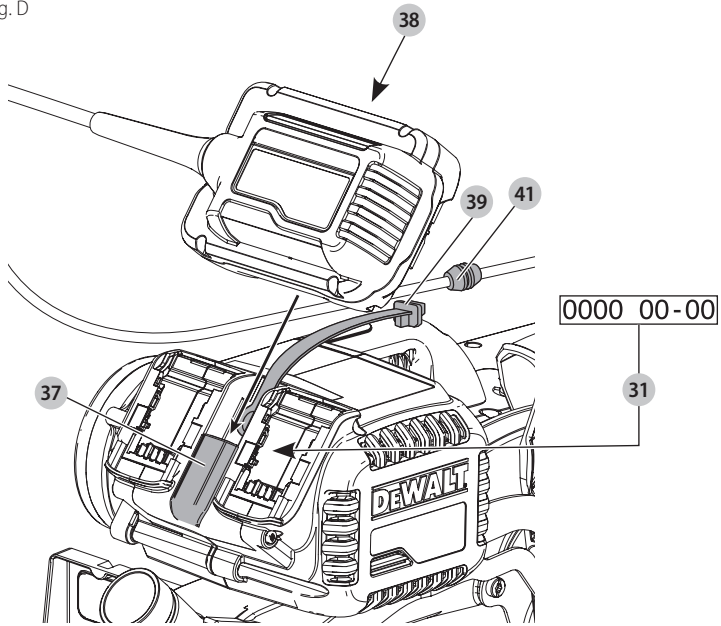

Fig. E

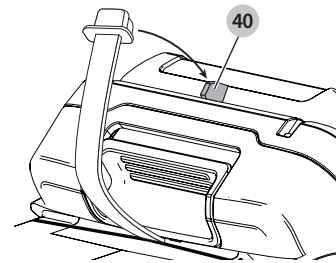

Fig. F

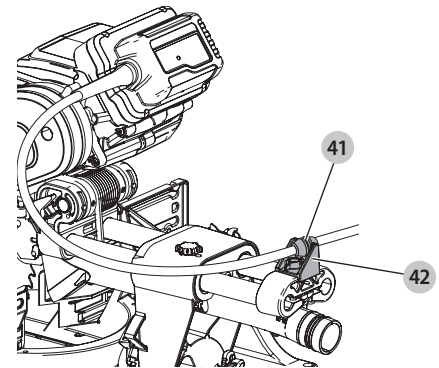

Fig. G

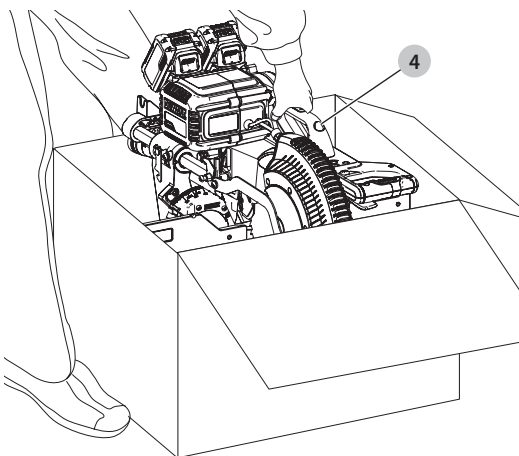

Fig. G1

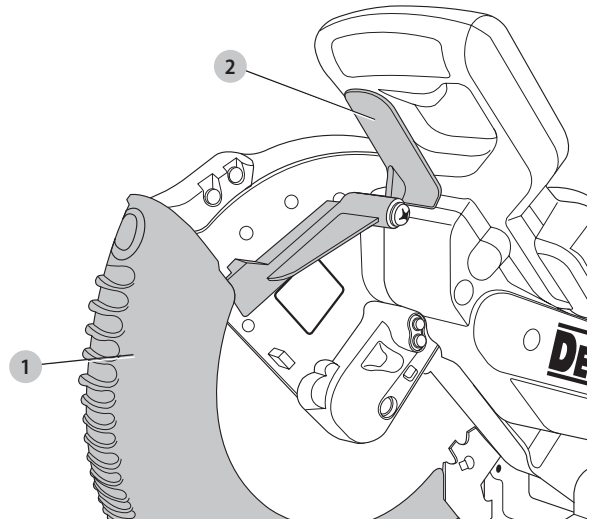

Fig. G2a

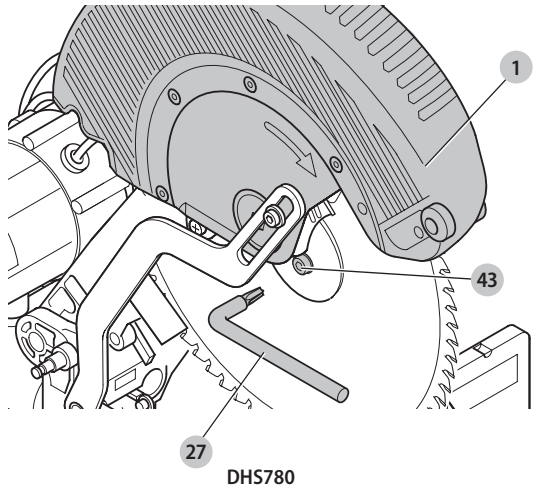

Fig. G2b

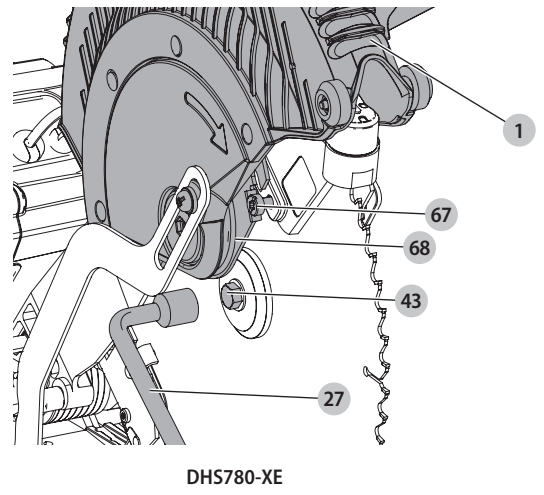

Fig. G3

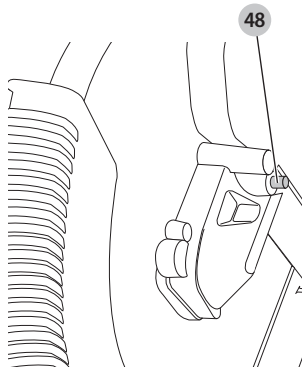

Fig. G4

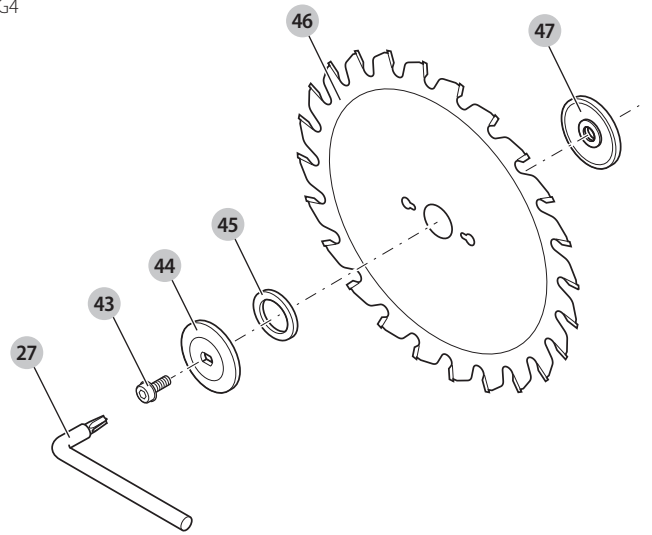

Fig. H

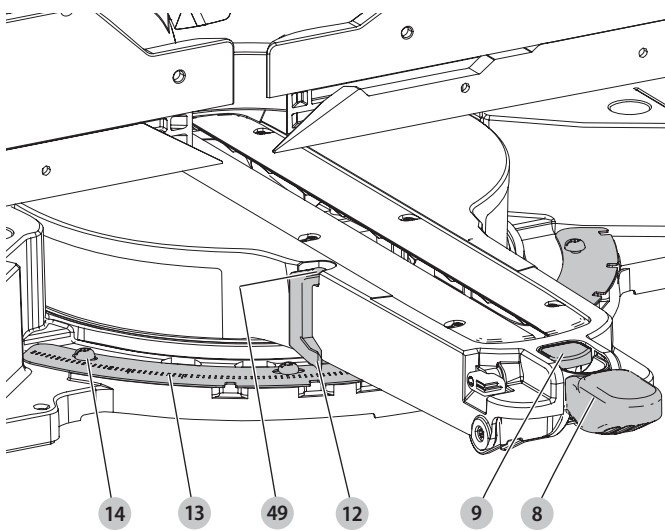

Fig. I

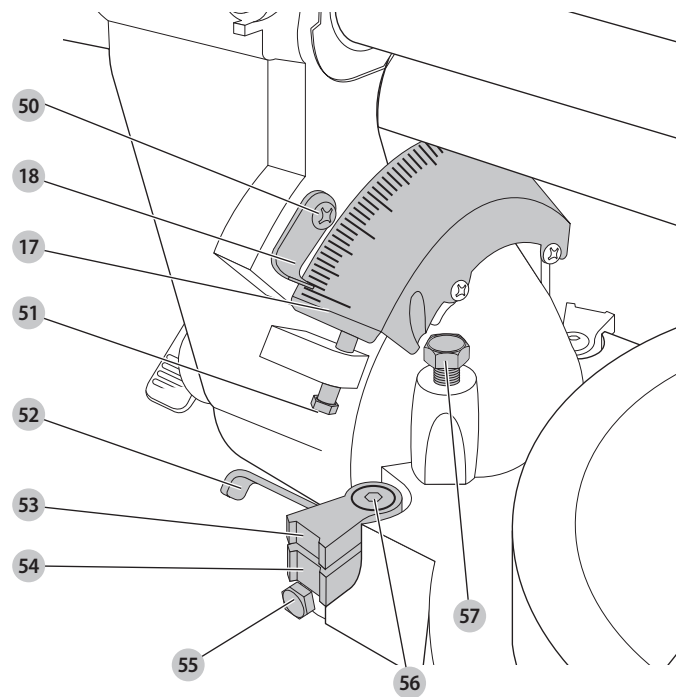

Fig. J

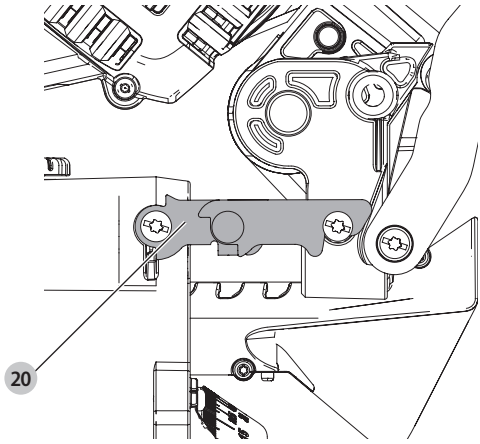

Fig. K

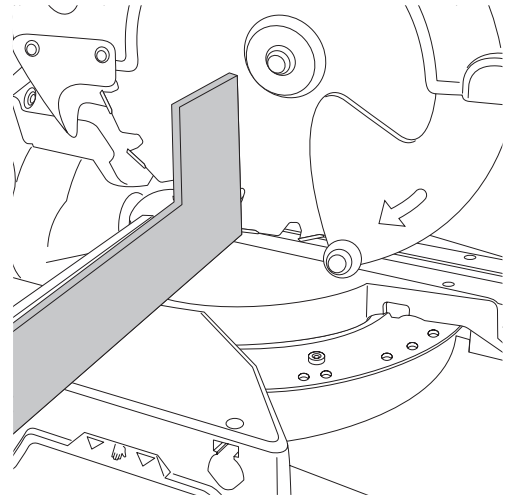

Fig. L

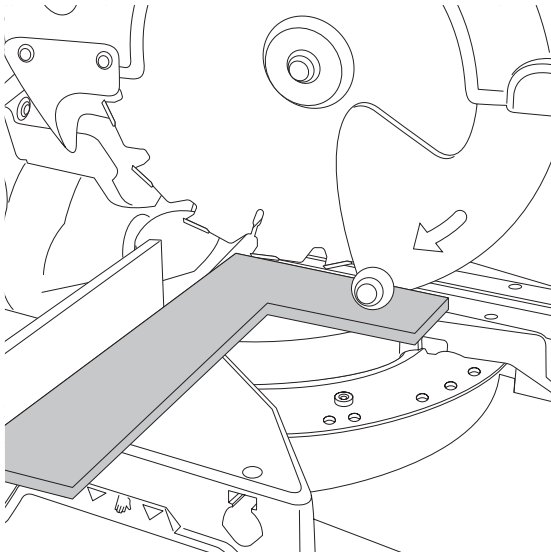

Fig. M

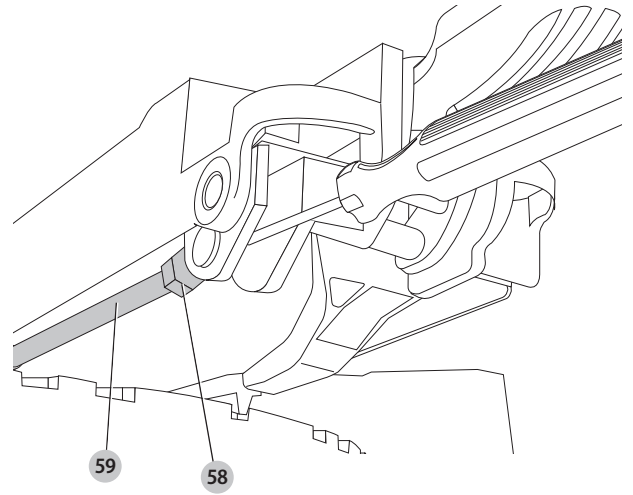

Fig. N1

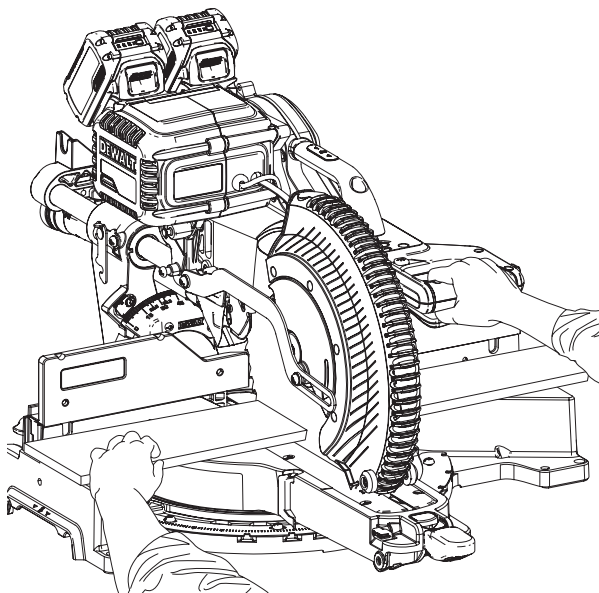

Fig. N2

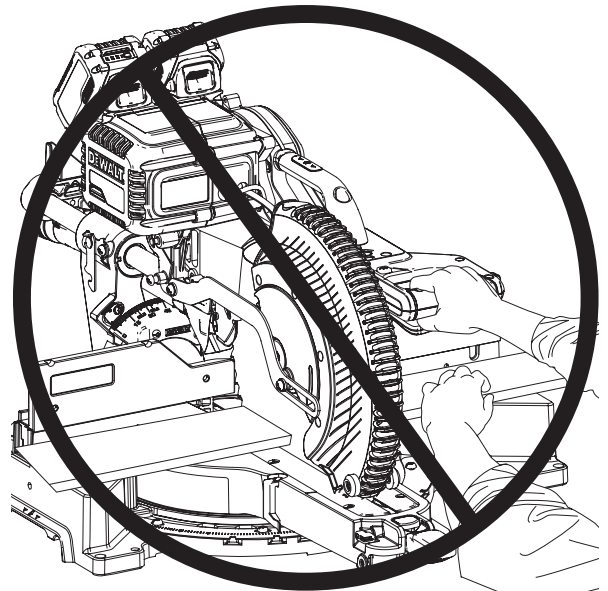

Fig. O

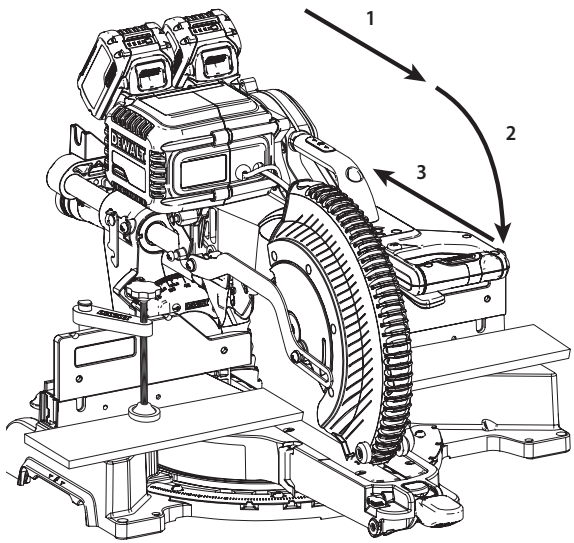

Fig. P

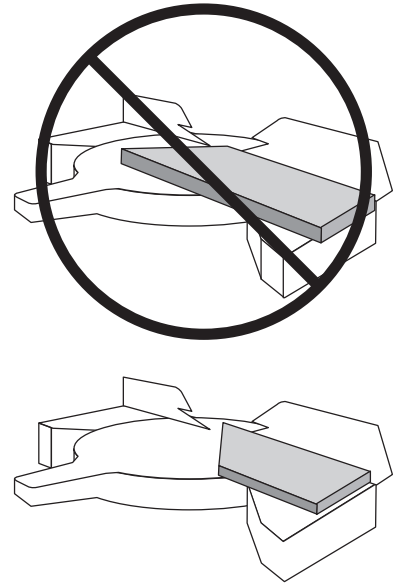

Fig. Q

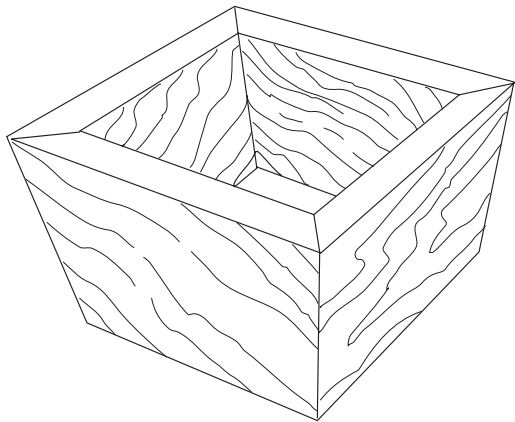

Fig. R

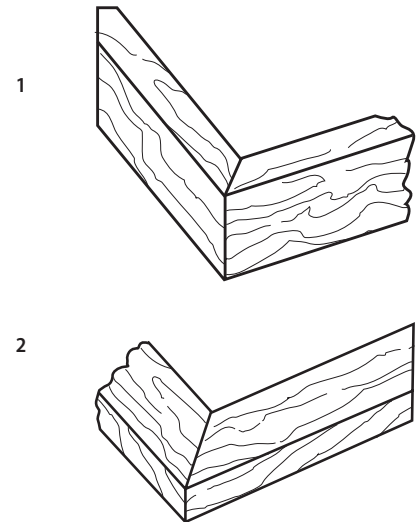

Fig. S

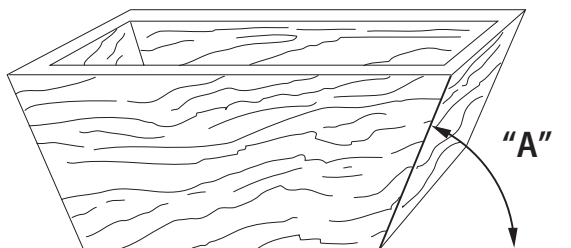

Fig. T

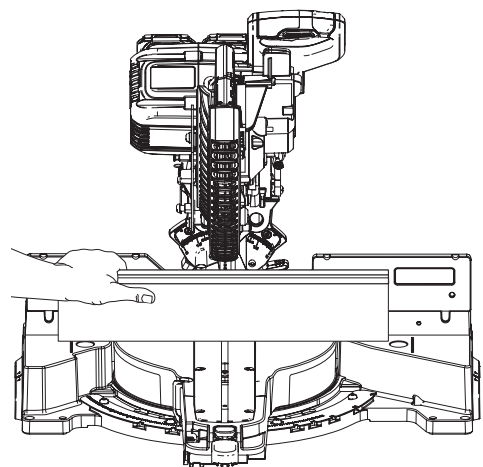

Fig. U1

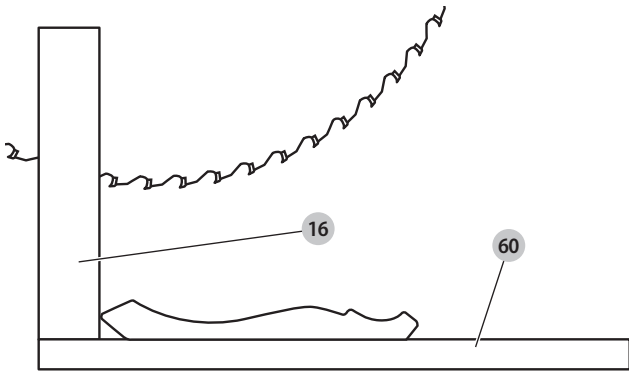

Fig. U2

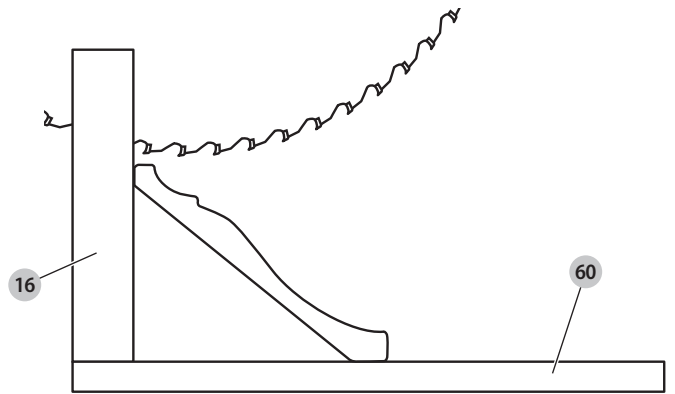

Fig. V1

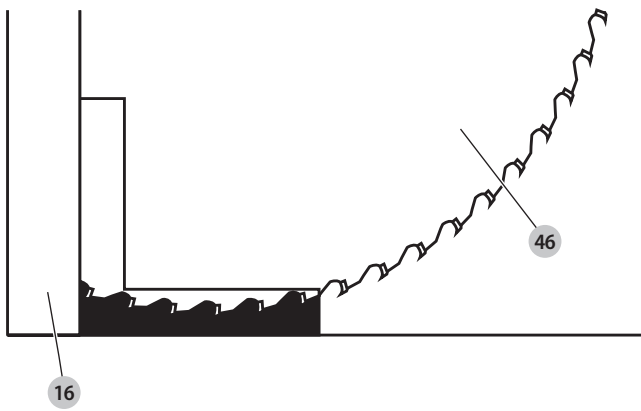

Fig. V2

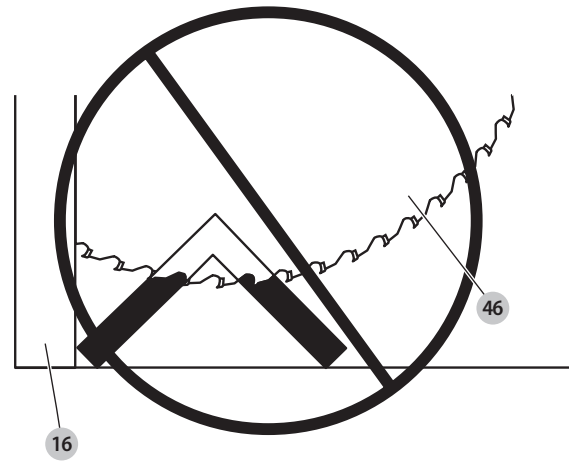

Fig. W1

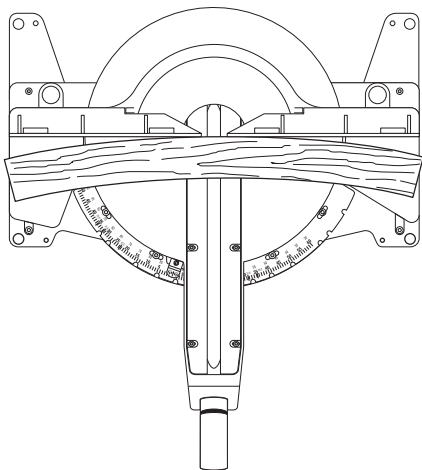

Fig. W2

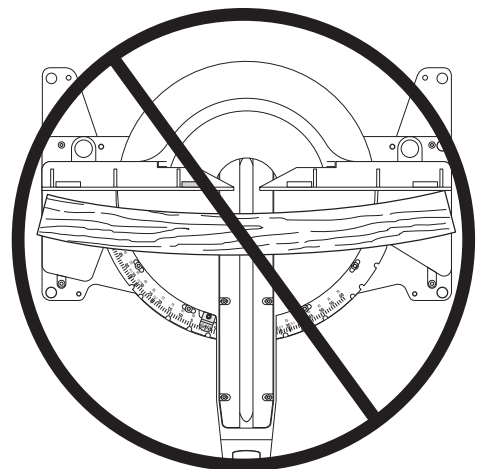

Fig. X

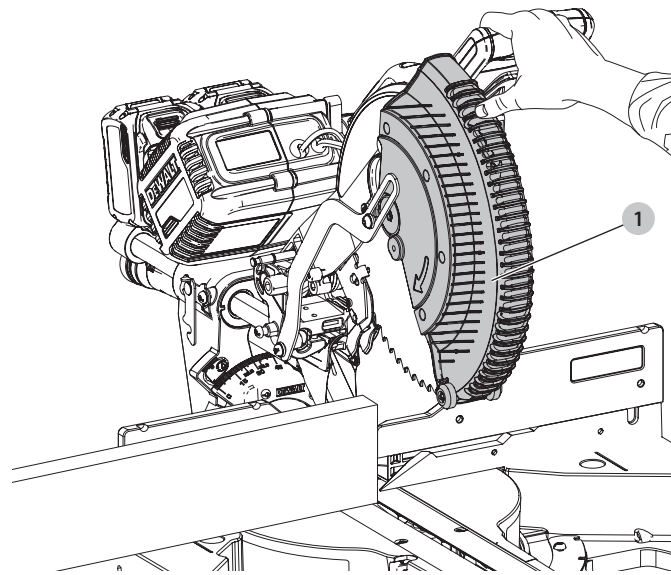

Fig. Y1

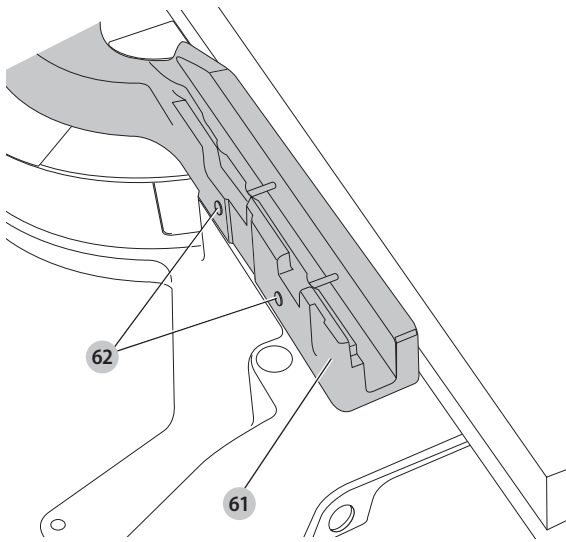

Fig. Y2

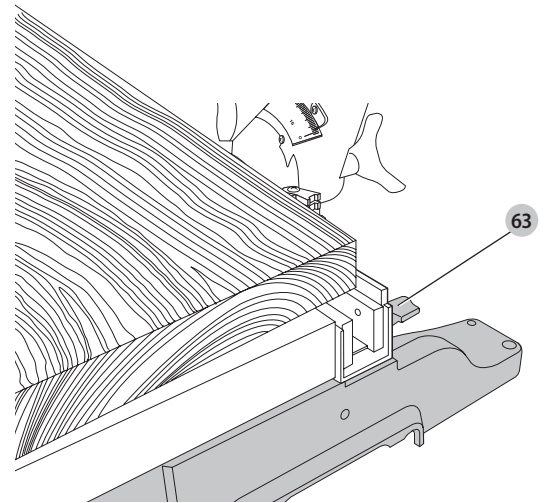
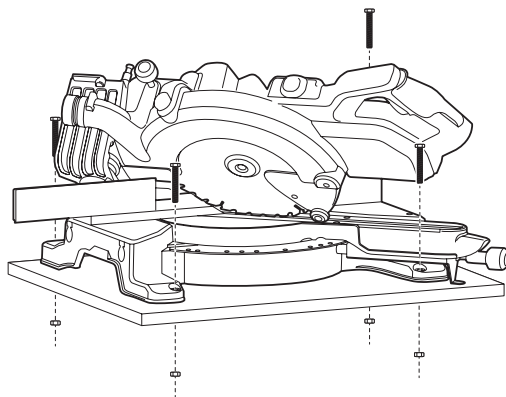

Fig. Z



MITRE SAW

DHS780

Congratulations!

You have chosen a DeWALT tool. Years of experience, thorough product development and innovation make DeWALT one of the most reliable partners for professional power tool users.

Technical Data

| | | DHS780 | DHS780-XE |
|---|-------------------|---------|-----------|
| Voltage | V _{AC} | 230 | 230 |
| UK & Ireland | V _{AC} | 230/115 | – |
| Type | | 20 | 20 |
| Current | A _{AC} | 8/15 | 8 |
| Battery Type | | Li-Ion | Li-Ion |
| Battery Voltage | V _{DC} | 2 x 54 | 2 x 54 |
| Blade diameter | mm | 305 | 305 |
| Blade bore | mm | 30 | 25.4 |
| Blade body thickness | mm | 1.6 | 1.6 |
| Max. blade speed | min ⁻¹ | 3 800 | 3 800 |
| Max. cross-cut capacity 90° | mm | 345 | 345 |
| Max. mitre capacity 45° | mm | 244 | 244 |
| Max. depth of cut 90° | mm | 112 | 112 |
| Max. depth of bevel cross-cut 45° | mm | 56 | 56 |
| Mitre (max. positions) | left | 50° | 50° |
| | right | 60° | 60° |
| Bevel (max. positions) | left | 49° | 49° |
| | right | 49° | 49° |
| 0° mitre | | | |
| Resulting width at max. height 112 mm | mm | 299 | 299 |
| Resulting width at max. height 110 mm | mm | 303 | 303 |
| Resulting height at max. width 345 mm | mm | 76 | 76 |
| 45° mitre left | | | |
| Resulting width at max. height 112 mm | mm | 200 | 200 |
| Resulting height at max. width 244 mm | mm | 76 | 76 |
| 45° mitre right | | | |
| Resulting width at max. height 112 mm | mm | 211 | 211 |
| Resulting height at max. width 244 mm | mm | 76 | 76 |
| 45° bevel left | | | |
| Resulting width at max. height 63 mm | mm | 268 | 268 |
| Resulting height at max. width 345 mm | mm | 44 | 44 |
| 45° bevel right | | | |
| Resulting width at max. height 62 mm | mm | 193 | 193 |
| Resulting height at max. width 345 mm | mm | 28 | 28 |
| Automatic blade brake time | s | < 5 | < 5 |
| Weight (without battery packs or corded power supply) | kg | 25.5 | 25.5 |

Noise values (tri-ax vector sum) according to EN61029-2-9

| | | 91 | 91 |
|---|-------|-----|-----|
| L _{PA} (emission sound pressure level) | dB(A) | 91 | 91 |
| L _{WA} (sound power level) | dB(A) | 102 | 102 |
| K (uncertainty for the given sound level) | dB(A) | 3 | 3 |

WARNING: The vibration emission level represents the main applications of the tool. However if the tool is used for different applications, with different accessories or poorly maintained, the vibration emission may differ. This may significantly increase the exposure level over the total working period.

An estimation of the level of exposure to vibration should also take into account the times when the tool is switched off or when it is running but not actually doing the job. This may significantly reduce the exposure level over the total working period.

Identify additional safety measures to protect the operator from the effects of vibration such as: maintain the tool and the accessories, keep the hands warm, organisation of work patterns.

EC-Declaration of Conformity

Machinery Directive



Mitre Saw DHS780

DeWALT declares that these products described under **Technical Data** are in compliance with: 2006/42/EC, EN61029-1:2009 +A11:2010, EN61029-2-9:2012 +A11:2013.

These products also comply with Directive 2014/30/EU and 2011/65/EU. For more information, please contact DeWALT at the following address or refer to the back of the manual.

The undersigned is responsible for compilation of the technical file and makes this declaration on behalf of DeWALT.

Markus Rempel
Director Engineering
DeWALT, Richard-Klinger-Straße 11,
D-65510, Idstein, Germany
28.02.2017



WARNING: To reduce the risk of injury, read the instruction manual.

Definitions: Safety Guidelines

The definitions below describe the level of severity for each signal word. Please read the manual and pay attention to these symbols.



DANGER: Indicates an imminently hazardous situation which, if not avoided, **will** result in **death or serious injury**.



WARNING: Indicates a potentially hazardous situation which, if not avoided, **could** result in **death or serious injury**.



CAUTION: Indicates a potentially hazardous situation which, if not avoided, **may** result in **minor or moderate injury**.

NOTICE: Indicates a practice **not related to personal injury** which, if not avoided, **may** result in **property damage**.



Denotes risk of electric shock.



Denotes risk of fire.

Safety Instructions



WARNING! When using electric tools basic safety precautions should always be followed to reduce the risk of fire, electric shock and personal injury including the following.

Read all these instructions before attempting to operate this product and save these instructions.

SAVE THIS MANUAL FOR FUTURE REFERENCE

General Safety Rules

- Keep work area clear.**
 - Cluttered areas and benches invite injuries.
- Consider work area environment.**
 - Do not expose the tool to rain. Do not use the tool in damp or wet conditions. Keep the work area well lit (250–300 Lux). Do not use the tool where there is a risk of causing fire or explosion, e.g., in the presence of flammable liquids and gases.
- Guard against electric shock.**
 - Avoid body contact with earthed surfaces (e.g., pipes, radiators, cookers and refrigerators). When using the tool under extreme conditions (e.g., high humidity, when metal swarf is being produced, etc.), electric safety can be improved by inserting an isolating transformer or a (FI) earth-leakage circuit-breaker.
- Keep other persons away.**
 - Do not let persons, especially children, not involved in the work, touch the tool or the extension cord and keep them away from the work area.
- Store idle tools.**
 - When not in use, tools must be stored in a dry place and locked up securely, out of reach of children.
- Do not force the tool.**
 - It will do the job better and safer at the rate to which it was intended.
- Use the right tool.**
 - Do not force small tools to do the job of a heavy duty tool. Do not use tools for purposes not intended; for example do not use circular saws to cut tree limbs or logs.
- Dress properly.**
 - Do not wear loose clothing or jewellery, as these can be caught in moving parts. Non-skid footwear is recommended when working outdoors. Wear protective hair covering to contain long hair.
- Use protective equipment.**
 - Always use safety glasses. Use a face or dust mask if working operations create dust or flying particles. If these particles might be considerably hot, also wear a heat-resistant apron. Wear ear protection at all times. Wear a safety helmet at all times.
- Connect dust extraction equipment.**
 - If devices are provided for the connection of dust extraction and collecting equipment, ensure these are connected and properly used.
- Do not abuse the charger cord or the DCB500 corded power supply cord.**
 - Never yank the cord to disconnect it from the socket.** Keep the cord away from heat, oil and sharp edges. Never carry the tool by its cord.

| Batteries | | | | Chargers/Charge Times (Minutes) | | | | | |
|-----------|-----------------|---------|-----------|---------------------------------|--------|--------|--------|--------|--------|
| Cat # | V _{DC} | Ah | Weight kg | DCB107 | DCB113 | DCB115 | DCB118 | DCB132 | DCB119 |
| DCB546 | 18/54 | 6.0/2.0 | 1.05 | 270 | 140 | 90 | 60 | 90 | X |
| DCB547 | 18/54 | 9.0/3.0 | 1.25 | 420 | 220 | 140 | 85 | 140 | X |
| DCB181 | 18 | 1.5 | 0.35 | 70 | 35 | 22 | 22 | 22 | 45 |
| DCB182 | 18 | 4.0 | 0.61 | 185 | 100 | 60 | 60 | 60 | 120 |
| DCB183/B | 18 | 2.0 | 0.40 | 90 | 50 | 30 | 30 | 30 | 60 |
| DCB184/B | 18 | 5.0 | 0.62 | 240 | 120 | 75 | 75 | 75 | 150 |
| DCB185 | 18 | 1.3 | 0.35 | 60 | 30 | 22 | 22 | 22 | X |
| DCB187 | 18 | 3.0 | 0.48 | 140 | 70 | 45 | 45 | 45 | 90 |

12. Secure work.

- Where possible use clamps or a vice to hold the work. It is safer than using your hand and it frees both hands to operate the tool.

13. Do not overreach.

- Keep proper footing and balance at all times.

14. Maintain tools with care.

- Keep cutting tools sharp and clean for better and safer performance. Follow instructions for lubricating and changing accessories. Inspect tools periodically and if damaged have them repaired by an authorized service facility. Keep handles and switches dry, clean and free from oil and grease.

15. Disconnect tools.

- When not in use, before servicing and when changing accessories such as blades, bits and cutters, disconnect tools from the power supply.

16. Remove adjusting keys and wrenches.

- Form the habit of checking to see that adjusting keys and wrenches are removed from the tool before operating the tool.

17. Avoid unintentional starting.

- Do not carry the tool with a finger on the switch. Be sure that the tool is in the "off" position before connecting to the power supply.

18. Use outdoor extension leads.

- Before use, inspect the extension cable and replace if damaged. When the tool is used outdoors, use only extension cords intended for outdoor use and marked accordingly.

19. Stay alert.

- Watch what you are doing. Use common sense. Do not operate the tool when you are tired or under the influence of drugs or alcohol.

20. Check for damaged parts.

- Before use, carefully check the tool and power supply to determine that it will operate properly and perform its intended function. Check for alignment of moving parts, binding of moving parts, breakage of parts, mounting and any other conditions that may affect its operation. A guard or other part that is damaged should be properly repaired or replaced by an authorized service centre unless otherwise indicated in this instruction manual. Have defective switches replaced by an authorized service centre. Do not use the tool if the switch does not turn it on and off. Never attempt any repairs yourself.



WARNING! The use of any accessory or attachment or performance of any operation with this tool other than those recommended in this instruction manual may present a risk of personal injury.

21. Have your tool repaired by a qualified person.

- This electric tool complies with relevant safety rules. Repairs should only be carried out by qualified persons using original spare parts; otherwise this may result in considerable danger to the user.

Additional Safety Rules for Mitre Saws

- The machine is provided with a special configured power supply cord which can only be replaced by the manufacturer or its authorised service agent.
- Do not use the saw to cut other materials than those recommended by the manufacturer.
- Do not operate the machine without guards in position, or if guards do not function or are not maintained properly.
- Ensure that the arm is securely fixed when performing bevel cuts.
- Keep the floor area around the machine level, well-maintained and free of loose materials, e.g., chips and cut-offs.
- Use correctly sharpened saw blades. Observe the maximum speed mark on the saw blade.
- Select the correct blade for the material to be cut.
- Make sure all locking knobs and clamp handles are tight before starting any operation.
- Never place either hand in the blade area when the saw is connected to the electrical power source.
- Do not reach behind the fence with either hand closer than 100 mm from either side of the saw blade, to remove wood scraps, or for any other reason while the blade is spinning. The proximity of the spinning saw blade to your hand may not be obvious and you may be seriously injured.
- Never attempt to stop a machine in motion rapidly by jamming a tool or other means against the blade; serious accidents can occur.
- Before using any accessory consult the instruction manual. The improper use of an accessory can cause damage.
- Use a holder or wear gloves when handling a saw blade or rough material.
- Ensure that the saw blade is mounted correctly before use.
- Make sure that the blade rotates in the correct direction.
- Do not use blades of larger or smaller diameter than recommended. For the proper blade rating refer to the **technical data**. Use only the blades specified in this manual, complying with EN 847-1.
- Do consider applying specially designed noise-reduction blades.
- Do not use HIGH SPEED STEEL blades.
- Do not use cracked or damaged saw blades.
- Do not use any abrasive or diamond discs.
- Never use your saw without the kerf plate.
- Before each cut ensure that the machine is stable.
- Raise the blade from the kerf in the workpiece prior to releasing the switch.
- Do not wedge anything against the fan to hold the motor shaft.
- The blade guard on your saw will automatically raise when the head up-lock release lever is pushed and the arm is brought down; it will lower over the blade as the arm is raised.
- Never raise the blade guard manually unless the saw is switched off. The guard can be raised by hand when installing or removing saw blades or for inspection of the saw.
- Check periodically that the motor air slots are clean and free of chips.
- Replace the kerf plate when worn. Refer to service parts list included.
- Disconnect the machine from the mains before carrying out any maintenance work or when changing the blade.
- Never perform any cleaning or maintenance work when the machine is still running and the head is not in the upper position.
- If you use an LED to indicate the cutting line, make sure that the LED is of class 2 according to EN62471. Do not replace an LED diode with a different type. If damaged, have the LED repaired by an authorised repair agent.
- The front section of the guard is lowered for visibility while cutting. Although the louvers dramatically reduce flying debris, they are openings in the guard and safety glasses should be worn at all times when viewing through the louvers.
- Connect the saw to a dust collection device when sawing wood. Always consider factors which influence exposure of dust such as:
 - type of material to be machined (chip board produces more dust than wood);
 - sharpness of the saw blade;
 - correct adjustment of the saw blade;
 - dust extractor with air velocity not less than 20m/s.
- Ensure that the local extraction as well as hoods, baffles and chutes are properly adjusted.
- Please be aware of the following factors influencing exposure to noise:
 - use saw blades designed to reduce the emitted noise;
 - use only well sharpened saw blades.
- Machine maintenance shall be conducted periodically.
- Provide adequate general or localized lighting.
- Ensure that any spacers and spindle rings are suitable for the purpose as stated in this manual.
- Refrain from removing any cut-offs or other parts of the workpiece from the cutting area while the machine is running and the saw head is not in the upper position.
- Never cut workpieces shorter than 200 mm.
- Without additional support the machine is designed to accept the maximum workpiece size for cross-cutting:
 - Maximum height: 112 mm
 - Maximum width: 345 mm
 - Maximum length: 600 mm
 - Longer workpiece needs to be supported by suitable additional support, e.g. DE7023-XJ or DE7033-XJ legstand. Always clamp the workpiece safely.
- In case of an accident or machine failure, immediately turn the machine off and disconnect machine from the power source.
- Report the failure and mark the machine in suitable form to prevent other people from using the defective machine.
- When the saw blade is blocked due to abnormal feed force during cutting, turn the machine off and disconnect it from power supply. Remove the workpiece and ensure that the saw blade runs free. Turn the machine on and start new cutting operation with reduced feed force.
- Never cut light alloy, especially magnesium.
- Whenever the situation allows, mount the machine to a bench using bolts with a diameter of 8 mm and 80 mm in length.

- Ensure the operator is adequately trained in the use, adjustment and operation of the machine.
- Before working select the correct saw blade for the material to be cut.
- Use only saw blades where the speed marked on the saw blade is at least equal to the speed marked on the rating blade.
- Ensure before each cut that the machine is located on an even and stable surface to prevent movement.

Residual Risks

In spite of the application of the relevant safety regulations and the implementation of safety devices, certain residual risks cannot be avoided. These are:

- Impairment of hearing.
- Risk of personal injury due to flying particles.
- Risk of burns due to accessories becoming hot during operation.
- Risk of personal injury due to prolonged use.

Electrical Safety

This machine has been designed to different voltages—battery supply 2x 54V and AC supply 115V or 230V. Always check that the battery pack voltage corresponds to the voltage on the rating plate. Also make sure that the voltage of your corded power supply and charger corresponds to that of your mains.



Your DeWALT tool, charger and corded power supply are double insulated in accordance with EN61029 and EN60335; therefore no earth wire is required.

- ⚠ **WARNING:** 115 V units have to be operated via a fail-safe isolating transformer with an earth screen between the primary and secondary winding.

Mains Plug Replacement (U.K. & Ireland Only)

If a new mains plug needs to be fitted:

- Safely dispose of the old plug.
- Connect the brown lead to the live terminal in the plug.
- Connect the blue lead to the neutral terminal.

- ⚠ **WARNING:** No connection is to be made to the earth terminal.

Follow the fitting instructions supplied with good quality plugs. Recommended fuse for the charger: 3 A. Recommended fuse for the corded power supply: 13A.

Using an Extension Cable for Your Charger or Corded Power Supply

An extension cord should not be used unless absolutely necessary. Use an approved extension cable suitable for the power input of your charger or corded power supply (see **Technical Data**). The minimum conductor size is 1.5 mm²; the maximum length is 30 m.

When using a cable reel, always unwind the cable completely.

Using the DCB500 Corded Power Supply

The DeWALT corded power supply is designed to provide power for DeWALT 2x 54 V FLEXVOLT™ cordless tools. Insert the corded power supply into the mitre saw battery slot (refer to **Installing and Removing the Corded Power Supply** and Figure D) and plug the power supply into an AC outlet. The power supply will act as the power source to the tool. Your DeWALT corded power supply should only be used with standard 230V household electric power supply. UK 115V units should be plugged into a 115V transformer.

The corded power supply is suitable for use with double insulated 2x 54V AC tools. The EU model of DCB500 has no ground contact.

Your DeWALT corded power supply should only be used with a power supply corresponding to the voltage on the rating plate of the DCB500 and not with DC power sources. Please check that the current rating of the tool is smaller or equal to the current rating of the power supply adapter.

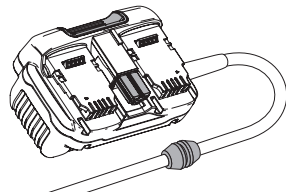

Additional Specific Usage Instructions

The corded power supply may become warm to the touch during use. This is a normal condition and does not indicate a problem.

IMPORTANT. The power supply is not user serviceable. There are no user serviceable parts inside the power supply. Cord replacement may be conducted at an authorized service centre.

SAVE THESE INSTRUCTIONS

Chargers

DeWALT chargers require no adjustment and are designed to be as easy as possible to operate.

Important Safety Instructions for All Battery Chargers

SAVE THESE INSTRUCTIONS: This manual contains important safety and operating instructions for compatible battery chargers (refer to **Technical Data**).

- Before using charger, read all instructions and cautionary markings on charger, battery pack, and product using battery pack.

- ⚠ **WARNING:** Shock hazard. Do not allow any liquid to get inside charger. Electric shock may result.

- ⚠ **WARNING:** We recommend the use of a residual current device with a residual current rating of 30mA or less.



CAUTION: Burn hazard. To reduce the risk of injury, charge only DeWALT rechargeable batteries. Other types of batteries may burst causing personal injury and damage.



CAUTION: Children should be supervised to ensure that they do not play with the appliance.

NOTICE: Under certain conditions, with the charger plugged into the power supply, the exposed charging contacts inside the charger can be shorted by foreign material. Foreign materials of a conductive nature such as, but not limited to, steel wool, aluminum foil or any buildup of metallic particles should be kept away from charger cavities. Always unplug the charger from the power supply when there is no battery pack in the cavity. Unplug charger before attempting to clean

- **DO NOT attempt to charge the battery pack with any chargers other than the ones in this manual.** The charger and battery pack are specifically designed to work together.
- **These chargers are not intended for any uses other than charging DeWALT rechargeable batteries.** Any other uses may result in risk of fire, electric shock or electrocution.
- **Do not expose charger to rain or snow.**
- **Pull by plug rather than cord when disconnecting charger.** This will reduce risk of damage to electric plug and cord.
- **Make sure that cord is located so that it will not be stepped on, tripped over, or otherwise subjected to damage or stress.**
- **Do not use an extension cord unless it is absolutely necessary.** Use of improper extension cord could result in risk of fire, electric shock, or electrocution.
- **Do not place any object on top of charger or place the charger on a soft surface that might block the ventilation slots and result in excessive internal heat.** Place the charger in a position away from any heat source. The charger is ventilated through slots in the top and the bottom of the housing.
- **Do not operate charger with damaged cord or plug—have them replaced immediately.**
- **Do not operate charger if it has received a sharp blow, been dropped, or otherwise damaged in any way.** Take it to an authorised service centre.
- **Do not disassemble charger; take it to an authorised service centre when service or repair is required.** Incorrect reassembly may result in a risk of electric shock, electrocution or fire.
- In case of damaged power supply cord the supply cord must be replaced immediately by the manufacturer, its service agent or similar qualified person to prevent any hazard.
- **Disconnect the charger from the outlet before attempting any cleaning. This will reduce the risk of electric shock.** Removing the battery pack will not reduce this risk.
- **NEVER attempt to connect two chargers together.**
- **The charger is designed to operate on standard 230V household electrical power. Do not attempt to use it on any other voltage.** This does not apply to the vehicular charger.

Charging a Battery (Fig. B)

1. Plug the charger into an appropriate outlet before inserting battery pack.
2. Insert the battery pack **22** into the charger, making sure the battery pack is fully seated in the charger. The red (charging) light will blink repeatedly indicating that the charging process has started.
3. The completion of charge will be indicated by the red light remaining ON continuously. The battery pack is fully charged and may be used at this time or left in the charger. To remove the battery pack from the charger, push the battery release button **32** on the battery pack.

NOTE: To ensure maximum performance and life of lithium-ion battery packs, charge the battery pack fully before first use.

Charger Operation

Refer to the indicators below for the charge status of the battery pack.

| Charge Indicators | | |
|-------------------|----------------------|--|
| | Charging | |
| | Fully Charged | |
| | Hot/Cold Pack Delay* | |

*The red light will continue to blink, but a yellow indicator light will be illuminated during this operation. Once the battery pack has reached an appropriate temperature, the yellow light will turn off and the charger will resume the charging procedure.

The compatible charger(s) will not charge a faulty battery pack. The charger will indicate faulty battery by refusing to light or by displaying problem pack or charger blink pattern.

NOTE: This could also mean a problem with a charger.

If the charger indicates a problem, take the charger and battery pack to be tested at an authorised service centre.

Hot/Cold Pack Delay

When the charger detects a battery pack that is too hot or too cold, it automatically starts a Hot/Cold Pack Delay, suspending charging until the battery pack has reached an appropriate temperature. The charger then automatically switches to the pack charging mode. This feature ensures maximum battery pack life.

A cold battery pack will charge at a slower rate than a warm battery pack. The battery pack will charge at that slower rate throughout the entire charging cycle and will not return to maximum charge rate even if the battery pack warms.

The DCB118 charger is equipped with an internal fan designed to cool the battery pack. The fan will turn on automatically when the battery pack needs to be cooled. Never operate the

charger if the fan does not operate properly or if ventilation slots are blocked. Do not permit foreign objects to enter the interior of the charger.

Electronic Protection System

XR Li-Ion tools are designed with an Electronic Protection System that will protect the battery pack against overloading, overheating or deep discharge.

The tool will automatically turn off if the Electronic Protection System engages. If this occurs, place the lithium-ion battery pack on the charger until it is fully charged.

Wall Mounting

These chargers are designed to be wall mountable or to sit upright on a table or work surface. If wall mounting, locate the charger within reach of an electrical outlet, and away from a corner or other obstructions which may impede air flow. Use the back of the charger as a template for the location of the mounting screws on the wall. Mount the charger securely using drywall screws (purchased separately) at least 25.4 mm long with a screw head diameter of 7–9 mm, screwed into wood to an optimal depth leaving approximately 5.5 mm of the screw exposed. Align the slots on the back of the charger with the exposed screws and fully engage them in the slots.

Charger Cleaning Instructions



WARNING: Shock hazard. Disconnect the charger from the AC outlet before cleaning. Dirt and grease may be removed from the exterior of the charger using a cloth or soft non-metallic brush. Do not use water or any cleaning solutions. Never let any liquid get inside the tool; never immerse any part of the tool into a liquid.

Battery Packs

Important Safety Instructions for All Battery Packs

When ordering replacement battery packs, be sure to include catalog number and voltage.

The battery pack is not fully charged out of the carton. Before using the battery pack and charger, read the safety instructions below. Then follow charging procedures outlined.

READ ALL INSTRUCTIONS

- **Do not charge or use battery in explosive atmospheres, such as in the presence of flammable liquids, gases or dust.** Inserting or removing the battery from the charger may ignite the dust or fumes.
- **Never force battery pack into charger. Do not modify battery pack in any way to fit into a non-compatible charger as battery pack may rupture causing serious personal injury.**
- Charge the battery packs only in DeWALT chargers.
- **DO NOT splash or immerse in water or other liquids.**
- **Do not store or use the tool and battery pack in locations where the temperature may reach or exceed 40 °C (104 °F) (such as outside sheds or metal buildings in summer).**
- **Do not incinerate the battery pack even if it is severely damaged or is completely worn out.** The battery pack can explode in a fire. Toxic fumes and materials are created when lithium-ion battery packs are burned.
- **If battery contents come into contact with the skin, immediately wash area with mild soap and water.** If battery liquid gets into the eye, rinse water over the open eye for 15 minutes or until irritation ceases. If medical attention is needed, the battery electrolyte is composed of a mixture of liquid organic carbonates and lithium salts.
- **Contents of opened battery cells may cause respiratory irritation.** Provide fresh air. If symptoms persists, seek medical attention.



WARNING: Burn hazard. Battery liquid may be flammable if exposed to spark or flame.



WARNING: Never attempt to open the battery pack for any reason. If battery pack case is cracked or damaged, do not insert into charger. Do not crush, drop or damage battery pack. Do not use a battery pack or charger that has received a sharp blow, been dropped, run over or damaged in any way (i.e., pierced with a nail, hit with a hammer, stepped on). Electric shock or electrocution may result. Damaged battery packs should be returned to service centre for recycling.



WARNING: Fire hazard. Do not store or carry the battery pack so that metal objects can contact exposed battery terminals. For example, do not place the battery pack in aprons, pockets, tool boxes, product kit boxes, drawers, etc., with loose nails, screws, keys, etc.

Transportation



WARNING: Fire hazard. Transporting batteries can possibly cause fire if the battery terminals inadvertently come in contact with conductive materials. When transporting batteries, make sure that the battery terminals are protected and well insulated from materials that could contact them and cause a short circuit.

DeWALT batteries comply with all applicable shipping regulations as prescribed by industry and legal standards which include UN Recommendations on the Transport of Dangerous Goods; International Air Transport Association (IATA) Dangerous Goods Regulations, International Maritime Dangerous Goods (IMDG) Regulations, and the European Agreement Concerning The International Carriage of Dangerous Goods by Road (ADR). Lithium-ion cells and batteries have been tested to section 38.3 of the UN Recommendations on the Transport of Dangerous Goods Manual of Tests and Criteria.

In most instances, shipping a DeWALT battery pack will be excepted from being classified as a fully regulated Class 9 Hazardous Material. In general, only shipments containing a lithium-ion battery with an energy rating greater than 100 Watt Hours (Wh) will require being shipped as fully regulated Class 9. All lithium-ion batteries have the Watt Hour rating marked on the pack. Furthermore, due to regulation complexities, DeWALT does not recommend air shipping lithium-ion battery packs alone regardless of Watt Hour rating. Shipments of tools with

batteries (combo kits) can be air shipped as excepted if the Watt Hour rating of the battery pack is no greater than 100 Whr.

Regardless of whether a shipment is considered excepted or fully regulated, it is the shipper's responsibility to consult the latest regulations for packaging, labeling/marketing and documentation requirements.

The information provided in this section of the manual is provided in good faith and believed to be accurate at the time the document was created. However, no warranty, expressed or implied, is given. It is the buyer's responsibility to ensure that its activities comply with the applicable regulations.

Transporting the FLEXVOLT™ Battery

The DeWALT FLEXVOLT™ battery has two modes: **Use and Transport.**

Use Mode: When the FLEXVOLT™ battery stands alone or is in a DeWALT 18V product, it will operate as an 18V battery. When the FLEXVOLT™ battery is in a 54V or a 2x 54V product, it will operate as a 54V battery.

Transport Mode: When the cap is attached to the FLEXVOLT™ battery, the battery is in Transport mode. Keep the cap for shipping.

When in Transport mode, strings of cells are electrically disconnected within the pack resulting in 3 batteries with a lower Watt hour (Wh) rating as compared to 1 battery with a higher Watt hour rating. This increased quantity of 3 batteries with the lower Watt hour rating can exempt the pack from certain shipping regulations that are imposed upon the higher Watt hour batteries.

For example, the Transport Wh rating might indicate 3 x 36 Wh, meaning 3 batteries of 36 Wh each. The Use Wh rating might indicate 108 Wh (1 battery implied).

Example of Use and Transport Label Marking



Storage Recommendations

1. The best storage place is one that is cool and dry away from direct sunlight and excess heat or cold. For optimum battery performance and life, store battery packs at room temperature when not in use.
2. For long storage, it is recommended to store a fully charged battery pack in a cool, dry place out of the charger for optimal results.

NOTE: Battery packs should not be stored completely depleted of charge. The battery pack will need to be recharged before use.

Labels on Charger and Battery Pack

In addition to the pictographs used in this manual, the labels on the charger and the battery pack may show the following pictographs:



Read instruction manual before use.



See **Technical Data** for charging time.



Do not probe with conductive objects.



Do not charge damaged battery packs.



Do not expose to water.



Have defective cords replaced immediately.



Charge only between 4 °C and 40 °C.



Only for indoor use.



Discard the battery pack with due care for the environment.



Charge DeWALT battery packs only with designated DeWALT chargers. Charging battery packs other than the designated DeWALT batteries with a DeWALT charger may make them burst or lead to other dangerous situations.



Do not incinerate the battery pack.



USE (without transport cap). Example: Wh rating indicates 108 Wh (1 battery with 108 Wh).



TRANSPORT (with built-in transport cap). Example: Wh rating indicates 3 x 36 Wh (3 batteries of 36 Wh).

Battery Type

The DHS780 operates on two 54 volt battery packs.

These battery packs may be used: DCB546, DCB547. Refer to **Technical Data** for more information.

Package Contents

The package contains:

- 1 DHS780 miter saw
- 1 Saw blade

In bag:

- 1 Blade wrench
- 1 Material clamp
- 1 Dustbag
- 1 Instruction manual

May include:

- 1 DCB500 DeWALT corded power supply
- 2 54V batteries
- 1 Dual port charger

- Check for damage to the tool, parts or accessories which may have occurred during transport.
- Take the time to thoroughly read and understand this manual prior to operation.

Markings on Tool

The following pictograms are shown on the tool:



Read instruction manual before use.



Wear ear protection.



Wear eye protection.



Carrying point.



Keep hands away from blade.



Do not stare directly into the light source.

Date Code Position (Fig. D)

The date code **31**, which also includes the year of manufacture, is printed into the housing.

Example:

2016 XX XX
Year of Manufacture

Description (Fig. A)



WARNING: Never modify the power tool or any part of it. Damage or personal injury could result.

- | | |
|--------------------------------|-----------------------------|
| 1 Lower guard | 19 Lock down pin |
| 2 Head up-lock release lever | 20 Slide lock lever |
| 3 Operating handle | 21 XPS™ on/off switch |
| 4 Carrying handle | 22 Battery packs |
| 5 Trigger switch | 23 Rails |
| 6 Trigger lock-off button | 24 Rail lock knob |
| 7 Bench mounting holes | 25 Rail adjustment screw |
| 8 Mitre lock handle | 26 Dust port |
| 9 Mitre release button | 27 Hex wrench |
| 10 Mitre detent override lever | 28 Bevel lock knob |
| 11 Kerf plate | 29 Clamp hole |
| 12 Mitre scale pointer | 30 Bevel stop override knob |
| 13 Mitre scale | 31 Date code (Fig. D) |
| 14 Mitre scale screws | 32 Battery release buttons |
| 15 Hand indentations | 33 Wing nut |
| 16 Fence | 34 Depth adjustment screw |
| 17 Bevel scale | 35 Grooving stop |
| 18 Bevel scale pointer | |

Intended Use

Your DeWALT DHS780 Mitre Saw has been designed for professional cutting of wood, wood products and plastics. It performs the sawing operations of cross-cutting, bevelling and mitring easily, accurately and safely.

This unit is designed for use with a nominal blade diameter 305 mm carbide tip blade.

DO NOT use under wet conditions or in the presence of flammable liquids or gases.

This mitre saw is professional power tools. **DO NOT** let children come into contact with the tool. Supervision is required when inexperienced operators use this tool.



WARNING! Do not use the machine for purposes other than intended.

- **Young children and the infirm.** This appliance is not intended for use by young children or infirm persons without supervision.

- This product is not intended for use by persons (including children) suffering from diminished physical, sensory or mental abilities; lack of experience, knowledge or skills unless they are supervised by a person responsible for their safety. Children should never be left alone with this product.

Unpacking (Fig. A, G)

1. Open the box and lift the saw out by the convenient carrying handle **4**, as shown in Figure G.
2. Place the saw on a smooth, flat surface.
3. Release the rail lock knob **24**, and push the saw head back to lock it in the rear position.
4. Press down lightly on the operating handle **3** and pull out the lock down pin **19**.
5. Gently release the downward pressure and hold the operating handle, allowing it to rise to its full height.

ASSEMBLY



WARNING: To reduce the risk of serious personal injury, turn tool off and remove the battery packs or power supply before transporting, making any adjustments, cleaning, repairing, or removing/installing attachments or accessories. An accidental start-up can cause injury.



WARNING: Use only DeWALT battery packs, corded power supply and chargers.

Bench Mounting (Fig. A, Z)

Holes **7** are provided in all four feet to facilitate bench mounting. Two different-sized holes are provided to accommodate different sizes of screws or bolts. Use either hole; it is not necessary to use both.

Always mount your saw firmly to a stable surface to prevent movement. To enhance the tool's portability, it can be mounted to a piece of 12.7 mm or thicker plywood which can then be clamped to your work support or moved to other job sites and reclamped.

NOTE: If you elect to mount your saw to a piece of plywood, make sure that the mounting screws or bolts don't protrude from the bottom of the wood. The plywood must sit flush on the work support. When clamping the saw to any work surface, clamp only on the clamping bosses where the mounting screw holes are located. Clamping at any other point will interfere with the proper operation of the saw.



CAUTION: To prevent binding and inaccuracy, be sure the mounting surface is not warped or otherwise uneven. If the saw rocks on the surface, place a thin piece of material under one saw foot until the saw sits firmly on the mounting surface.

Installing and Removing the Battery Packs from the Tool (Fig. C1)

NOTE: For best results, make sure your battery packs are fully charged.

To install the battery packs **22** into the tool, align the battery packs with the rails on the side of the motor housing and slide them in until they are firmly seated in the tool and ensure that they do not disengage. Insert the dust cover **39** into the corded power supply receptacle **37** in between the batteries.

NOTICE: Keep the dust cover in place whenever the corded power supply is not in use.

To remove the battery packs from the tool, press the battery release button **32** and firmly pull the battery packs out. Insert them into the charger as described in the charger section of this manual.

Fuel Gauge Battery Packs (Fig. C2)

Some DeWALT battery packs include a fuel gauge which consists of three green LED lights that indicate the level of charge remaining in the battery pack.

To actuate the fuel gauge, press and hold the fuel gauge button. A combination of the three green LED lights will illuminate designating the level of charge left. When the level of charge in the battery is below the usable limit, the fuel gauge will not illuminate and the battery will need to be recharged.

NOTE: The fuel gauge is only an indication of the charge left on the battery pack. It does not indicate tool functionality and is subject to variation based on product components, temperature and end-user application.

Installing and Removing the Corded Power Supply into and from Tool (Fig. D–F)

Before inserting the corded power supply into your tool, remove the end of the dust cover **39** from the tool's corded power supply receptacle **37**. Pull the dust cover away from the tool's corded power supply receptacle so that it does not interfere with insertion of the corded power supply. Inspect the corded power supply receptacle for debris. Debris inside the receptacle can prevent the corded power supply from fully seating. If debris is present, clean it using low pressure air. Refer to **Cleaning the Corded Power Supply Receptacle**.

NOTICE: The corded power supply is for AC power sources only when used with this tool. Use with DC power sources could result in damage to the tool.

To install the corded power supply into your tool:

1. With the corded power supply unplugged, align its AC connector with the tool's corded power supply receptacle **37** then snap into place.
2. Ensure that it is fully seated in the tool and does not disengage.
3. Attach the dust cover **39** to the dust cover holder (**40**, Fig. E) in the corded power supply.
4. Secure the cord clip **41** into the tool's cord clip holder (**42**, Fig. F). Firmly press the clip into the holder.

- With the tool turned off, plug the corded power supply into a standard 230 V household electric power outlet. UK 115V units should be plugged into a 115V transformer. Do not attempt to use the corded power supply on any other voltage.
- Use the tool according to the tool instructions, making sure the cord is located so that it will not be stepped on, tripped over, or otherwise subjected to damage or stress.
- To remove the corded power supply from the tool, first unplug the corded power supply from the outlet, then press the release button **38** and firmly pull the corded power supply out of the tool. Firmly press the end of the dust cover **39** into the tool's corded power supply receptacle **37**.

Changing or Installing a New Saw Blade

Removing the Blade (Fig. A, G1–G4)

WARNING: To reduce the risk of serious personal injury, turn tool off and remove the battery packs or power supply before transporting, making any adjustments, cleaning, repairing, or removing/installing attachments or accessories. Be sure the trigger switch is in the OFF position. An accidental start-up can cause injury.

- Never depress the spindle lock button while the blade is under power or coasting.
- Do not cut light alloy and ferrous metal (containing iron or steel) or masonry or fibre cement product with this mitre saw.

DHS780 (FIG. G1, G2a, G3, G4)

- Disconnect the saw from the power supply or remove batteries.
- Depress the head up-lock release lever **2** to release the lower guard **1**, then raise the lower guard as far as possible.
- Depress the spindle lock button **48** while carefully rotating the saw blade by hand until the lock engages.
- Keeping the button depressed, use the other hand and the wrench **27** provided to loosen the blade screw. (Turn clockwise, left-hand threads.)
- Remove the blade screw **43**, outer clamp washer **44**, adapter **45** and blade **46**. The inner clamp washer **47** may be left on the spindle.

DHS780-XE ONLY (FIG. G1, G2b, G4)

- Disconnect the saw from the power supply or remove batteries.
- Depress the head up-lock release lever **2** to release the lower guard **1**, then raise the lower guard as far as possible.
- Loosen, but do not remove guard bracket screw **67** until the guard bracket **68** can be raised far enough to access the blade screw **43**. Lower guard will remain raised due to the position of the guard bracket screw.
- Depress the spindle lock button **48** while carefully rotating the saw blade by hand until the lock engages.
- Keeping the button depressed, use the other hand and the wrench provided **27** to loosen the blade screw **43**. (Turn clockwise, left-hand threads.)
- Remove the blade screw **43**, outer clamp washer **44**, adapter **45** and blade **46**. The inner clamp washer **47** may be left on the spindle.

NOTE: For blades with a blade hole of 15.88 mm, the 25.4 mm blade adapter is not used.

Installing a Blade (Fig. A, G1–G4)

- Disconnect the saw from the power supply or remove batteries.
- With the arm raised and the lower guard held open, place the adapter and blade on the spindle, and seat it on the inner blade clamp with the teeth at the bottom of the blade pointing toward the back of the saw.
- Assemble the outer clamp washer onto the spindle.
- Install the blade screw and, engaging the spindle lock, tighten the screw firmly with wrench provided (turn counterclockwise, left-hand threads).
- DSH780-XE ONLY, GIG G2b:** Return the guard bracket **68** to its original position and firmly tighten the guard bracket screw **67** to hold bracket in place.

WARNING: The guard bracket must be returned to its original position and the guard bracket screw tightened before activating the saw. Failure to do so may allow the guard to contact the spinning saw blade resulting in damage to the saw and severe personal injury.

WARNING! Be aware the saw blade shall be replaced in the described way only. Only use saw blades as specified under **Technical Data**; Cat. no.: DT4260 is suggested.

Transporting the Saw (Fig. A)

WARNING: To reduce the risk of serious personal injury, ALWAYS lock the rail lock knob, mitre lock handle, bevel lock handle, lock down pin and fence adjustment knobs before transporting saw. Never use guards for transporting or lift up.

In order to conveniently carry the mitre saw, a carrying handle **4** has been included on the top of the saw arm.

- To transport the saw, lower the head and depress the lock down pin **19**.
- Lock the rail lock knob with the saw head in the front position, lock the mitre arm in the full left mitre angle, slide the fence **16** completely inward and lock the bevel lock knob **28** with the saw head in the vertical position to make the tool as compact as possible.
- Always use the carrying handle **4** or the hand indentations **15**.

Features and Controls

WARNING: To reduce the risk of serious personal injury, turn tool off and remove the battery packs or power supply before transporting, making any adjustments, cleaning, repairing, or removing/installing attachments or accessories. Be sure the trigger switch is in the OFF position. An accidental start-up can cause injury.

Mitre Control (Fig. H)

The mitre lock handle **8** and mitre release button **9** allow you to mitre your saw to 60° right and 50° left. To mitre the saw, lift the mitre lock handle, push the mitre release button and set the mitre angle desired on the mitre scale **13**. Push down on the mitre lock handle to lock the mitre angle.

Bevel Lock Knob (Fig. A)

The bevel lock allows you to bevel the saw 49° left or right. To adjust the bevel setting, turn the knob **28** counterclockwise. The saw head bevels easily to the left or to the right once the 0° bevel override knob is pulled. To tighten, turn the bevel lock knob clockwise.

0° Bevel Override (Fig. A)

The bevel stop override **30** allows you to bevel the saw to the right past the 0° mark.

When engaged, the saw will automatically stop at 0° when brought up from the left. To temporarily move past 0° to the right, pull the bevel lock knob **28**. Once the knob is released, the override will be reengaged. The bevel lock knob can be locked out by twisting the knob 180°.

When at 0°, the override locks in place. To operate the override, bevel the saw slightly to the left.

45° Bevel Stop Override (Fig. I)

There are two bevel stop override levers, one on each side of the saw. To bevel the saw, left or right, past 45°, push the 45° bevel override lever **52** rearward. When in the rearward position, the saw can bevel past these stops. When the 45° stops are needed, pull the 45° bevel override lever forward.

Crown Bevel Pawls (Fig. I)

NOTE: Crown bevel cuts can be made using hard stops for a fast and accurate setting at 30° and 33.9°.

When cutting crown molding laying flat, your saw is equipped to accurately and rapidly set a crown stop, left or right (refer to **Instructions for Cutting Crown Molding Laying Flat and Using the Compound Features**).

The 30° crown bevel pawl **54** can be rotated to contact the crown adjustment screw **51**.

To reverse the 30° crown bevel pawl to 33.9°, remove the retaining screw **56**, the 22.5° bevel pawl **53** and the 30° crown bevel pawl **54**. Flip the 30° crown bevel pawl **54** so the 33.9° text is facing up. Reattach the retaining screw **56** to secure the 22.5° bevel pawl and the 33.9° crown bevel pawl. The accuracy setting will not be affected.

22.5° Bevel Pawls (Fig. I)

Your saw is equipped to rapidly and accurately set a 22.5° bevel, left or right. The 22.5° bevel pawl **53** can be rotated to contact the crown adjustment screw **51**.

Rail Lock Knob (Fig. A)

The rail lock knob **24** allows you to lock the saw head firmly to keep it from sliding on the rails **23**. This is necessary when making certain cuts or when transporting the saw.

Grooving Stop (Fig. A)

The grooving stop **35** allows the depth of cut of the blade to be limited. The stop is useful for applications such as grooving and tall vertical cuts. Rotate the grooving stop forward and adjust the depth adjustment screw **34** to set the desired depth of cut. To secure the adjustment, tighten the wing nut **33**. Rotating the grooving stop to the rear of the saw will bypass the grooving stop feature. If the depth adjustment screw is too tight to loosen by hand, the provided wrench **27** can be used to loosen the screw.

Lock Down Pin (Fig. A)

WARNING: The lock down pin should be used only when carrying or storing the saw. NEVER use the lock down pin for any cutting operation.

To lock the saw head in the down position, push the saw head down, push the lock down pin **19** in and release the saw head. This will hold the saw head safely down for moving the saw from place to place. To release, press the saw head down and pull the pin out.

Adjustment

Your mitre saw is fully and accurately adjusted at the factory at the time of manufacture. If readjustment due to shipping and handling or any other reason is required, follow the instructions below to adjust your saw. Once made, these adjustments should remain accurate.

Mitre Scale Adjustment (Fig. H, L)

- Unlock the mitre lock handle **8** and swing the mitre arm until the mitre release button **9** locks it at the 0° mitre position. Do not lock the mitre lock handle.
- Place a square against the saw's fence and blade, as shown in Figure L. (Do not touch the tips of the blade teeth with the square. To do so will cause an inaccurate measurement.)
- If the saw blade is not exactly perpendicular to the fence, loosen the four screws **14** that hold the mitre scale **13** and move the mitre lock handle and the scale left or right until the blade is perpendicular to the fence, as measured with the square.
- Retighten the four screws. Pay no attention to the reading of the mitre pointer **12** at this time.

Mitre Pointer Adjustment (Fig. H)

- Unlock the mitre lock handle **8** to move the mitre arm to the zero position.
- With the mitre lock handle unlocked, allow the mitre latch to snap into place as you rotate the mitre arm to zero.
- Observe the mitre pointer **12** and mitre scale **13** shown in Figure H. If the pointer does not indicate exactly zero, loosen the mitre pointer screw **49** holding the pointer in place, reposition the pointer and tighten the screw.

Bevel Square to Table Adjustment (Fig. A, I, L)

- To align the blade square to the table, lock the arm in the down position with the lock down pin **19**.
- Place a square against the blade, ensuring the square is not on top of a tooth (Fig. L).
- Loosen the bevel lock knob **28** and ensure the arm is firmly against the 0° bevel stop.
- Rotate the 0° bevel adjustment screw (**57** Fig. I) with the 13 mm blade hex wrench **27** as necessary so that the blade is at 0° bevel to the table.

Bevel Pointer Adjustment (Fig. I)

If the bevel pointers **18** do not indicate zero, loosen each screw **50** that holds each bevel pointer in place and move them as necessary. Ensure the 0° bevel is correct and the bevel pointers are set before adjusting any other bevel angle screws.

Bevel Stop 45° Right and Left Adjustment (Fig. A, I)

To adjust the right 45° bevel stop:

- Loosen the bevel lock knob **28** and pull the bevel stop override knob **30** to override the 0° bevel stop.
- If the bevel pointer **18** does not indicate exactly 45° when the saw is fully to the right and the 45° bevel adjustment screw **55** is contacting the 45° bevel override lever, turn the left 45° bevel adjustment screw **55** with the 13 mm blade hex wrench **27** (provided with some units) until the bevel pointer indicates 45°. Ensure the 45° bevel override lever **52** is in contact with the 45° bevel adjustment screw **55**.

To adjust the left 45° bevel stop:

- Loosen the bevel lock knob **28** and tilt the head to the left.
- If the bevel pointer **18** does not indicate exactly 45°, turn the right 45° bevel adjustment screw **55** until the bevel pointer reads 45°.

Adjusting the Bevel Stop to 22.5° (or 30°) (Fig. A, I)

NOTE: Adjust the bevel angles only after performing the 0° bevel angle and bevel pointer adjustment.

To set the left 22.5° bevel angle, flip out the left 22.5° bevel pawl **53**. Loosen the bevel lock knob **28** and tilt the head fully to the left. If the bevel pointer **18** does not indicate exactly 22.5°, turn the crown adjustment screw **51** contacting the pawl with a 10 mm wrench (not provided) until the bevel pointer reads 22.5°.

To adjust the right 22.5° bevel angle, flip out the right 22.5° bevel pawl **53**. Loosen the bevel lock knob **28** and pull the bevel stop override knob **30** to override the 0° bevel stop. When the saw is fully to the right, if the bevel pointer does not indicate exactly 22.5°, turn the crown adjustment screw **51** contacting the pawl with a 10 mm wrench until the bevel pointer indicates exactly 22.5°.

Fence Adjustment (Fig. A, Y2)

The upper part of the fence can be adjusted to provide clearance, allowing the saw to bevel to a full 49° both left and right.

- To adjust each fence **16**, loosen the fence adjustment knob **63** and slide the fence outward.
- Make a dry run with the saw turned off and check for clearance.
- Adjust the fence to be as close to the blade as practical to provide maximum workpiece support, without interfering with arm up and down movement.
- Tighten the fence adjustment knob securely.
- When the bevel operations are complete, relocate the fence.

For certain cuts, it may be desirable to bring the fences closer to the blade. To do so, back the fence adjustment knobs **63** out two turns and move the fences closer to the blade past the normal limit, then tighten the fence adjustment knobs. Make a dry cut first to ensure the blade does not contact the fences.

NOTE: The tracks of the fences can become clogged with sawdust. Use a brush or some low pressure air to clear the guide grooves.

Guard Actuation and Visibility (Fig. A)

The lower guard **1** on your saw has been designed to automatically uncover the blade when the arm is brought down and to cover the blade when the arm is raised.

The guard can be raised by hand when installing or removing saw blades or for inspection of the saw. NEVER RAISE THE LOWER GUARD MANUALLY UNLESS THE BLADE IS STOPPED.

Kerf Plate Adjustment (Fig. A)

To adjust the kerf plates **11**, loosen the 6 screws holding the kerf plates in place. Adjust so that the kerf plates are as close as possible without interfering with the blade's movement.

If a zero kerf width is desired, adjust the kerf plates as close to each other as possible. They can now be cut slowly with the saw blade to give the smallest gap possible between the blade and the kerf plates.

Rail Guide Adjustment (Fig. A)

Regularly check the rails **23** for play or clearance. Ensure the rail lock knob **24** is loosened. The right rail can be adjusted with the rail adjustment screw **25**. To reduce clearance, use a 4 mm hex wrench (not provided) and rotate the set screw clockwise gradually while sliding the saw head back and forth.

Mitre Lock Adjustment (Fig. A, M)

The mitre lock rod **59** should be adjusted if the table of the saw can be moved when the mitre lock handle is locked (down) and in a non-detented position.

- Put the mitre lock handle **8** in the unlocked (up) position.
- Using a 13 mm open end wrench, loosen the lock nut **58** on the mitre lock rod.
- Using a slotted screwdriver, tighten the mitre lock rod by turning it clockwise as shown in Figure M. Turn the lock rod until it is snug, then turn counterclockwise one turn.

- Re-lock the mitre lock to a non-detented measurement on the mitre scale – for example, 34° – and make sure the table will not rotate.
- Tighten lock nut.

Prior to Operation

- Install the appropriate saw blade. Do not use excessively worn blades. The maximum rotation speed of the tool must not exceed that of the saw blade. Do not use any abrasive blades.
- Do not attempt to cut excessively small pieces.
- Allow the blade to cut freely. Do not force.
- Allow the motor to reach full speed before cutting.
- Make sure all locking knobs and clamp handles are tight.
- Secure the workpiece.
- Although this saw will cut wood and many nonferrous materials, these operating instructions refer to the cutting of wood only. The same guidelines apply to the other materials. Do not cut ferrous (iron and steel) materials, fibre cement or masonry with this saw!
- Make sure to use the kerf plate. Do not operate the machine if the kerf slot is wider than 10 mm.

OPERATION

Instructions for Use

! WARNING: Always observe the safety instructions and applicable regulations.

! WARNING: To reduce the risk of serious personal injury, turn tool off and remove the battery packs or power supply before transporting, making any adjustments, cleaning, repairing, or removing/installing attachments or accessories. Be sure the trigger switch is in the OFF position. An accidental start-up can cause injury.

Refer to **Saw Blades** under **Optional Accessories** to select the blade that best fits your needs.

Ensure the machine is placed to satisfy your ergonomic conditions in terms of table height and stability. The machine site shall be chosen so that the operator has a good overview and enough free surrounding space around the machine that allows handling of the workpiece without any restrictions.

To reduce effects of vibration make sure the environment temperature is not too cold, the machine and accessories are well maintained and the workpiece size is suitable for this machine.

The attention of UK users is drawn to the "woodworking machines regulations 1974" and any subsequent amendments.

Proper Body and Hand Position (Fig. N1, N2)

! WARNING: To reduce the risk of serious personal injury, ALWAYS use proper hand position as shown in Figure N1.

! WARNING: To reduce the risk of serious personal injury, ALWAYS hold securely in anticipation of a sudden reaction.

- Never place hands near cutting area. Place hands no closer than 100 mm from the blade.
- Hold the workpiece tightly to the table and the fence when cutting. Keep hands in position until the trigger has been released and the blade has completely stopped.
- ALWAYS MAKE DRY RUNS (UNPOWERED) BEFORE FINISH CUTS SO THAT YOU CAN CHECK THE PATH OF THE BLADE. DO NOT CROSS HANDS, AS SHOWN IN FIGURE N2.
- Keep both feet firmly on the floor and maintain proper balance. As you move the mitre arm left and right, follow it and stand slightly to the side of the saw blade.
- Sight through the guard louvers when following a pencil line.

Switching On and Off (Fig. A)

To turn the saw on, depress the trigger switch **5**. To turn the tool off, release the trigger switch. Allow the blade to spin up to full operating speed before making the cut.

Release the trigger switch and allow the brake to stop the blade before raising the saw head.

A hole is provided in the trigger switch for insertion of a padlock to lock the saw off.

Use of XPS™ LED Worklight System (Fig. A)

NOTE: The mitre saw must be connected to a power source.

The XPS™ LED Worklight System can be turned on by the momentary switch **21**. The light will automatically turn off within 20 seconds if the saw is not in use. The light will activate automatically every time the tool's main trigger **5** is pulled.

To cut through an existing pencil line on a piece of wood:

- Turn on the XPS™ system, then pull down on the operating handle **3** to bring the saw blade close to the wood. The shadow of the blade will appear on the wood.
- Align the pencil line with the edge of the blade's shadow. You may have to adjust the mitre or bevel angles in order to match the pencil line exactly.

Dust Extraction (Fig. A)

! WARNING: To reduce the risk of serious personal injury, turn tool off and remove the battery packs or power supply before transporting, making any adjustments, cleaning, repairing, or removing/installing attachments or accessories. An accidental start-up can cause injury.

! WARNING: Certain dust, such as oak or beech dust, is considered carcinogenic, especially in connection with wood-treatment additives.

- Always use dust extraction.
- Provide for good ventilation of the work space.
- It is recommended to wear an appropriate respirator.

Your saw has a built-in dust port **26** that allows you to connect the supplied dust bag or a shop vacuum system using either the AirLock™ system (DWV9000-XJ) or a standard 35 mm dust extractor fitment.

WARNING: ALWAYS use a vacuum extractor designed in compliance with the applicable directives regarding dust emission when sawing wood. Vacuum hoses of most common vacuum cleaners will fit directly into the dust extraction port.

To Attach the Dust Bag

1. Fit the dust bag to the dust port **26**.

To Empty the Dust Bag

1. Remove dust bag from the saw and gently shake or tap the dust bag to empty.
2. Reattach the dust bag back onto the dust port **26**.

You may notice that all the dust will not come free from the bag. This will not affect cutting performance but will reduce the saw's dust collection efficiency. To restore your saw's dust collection efficiency, depress the spring inside the dust bag when you are emptying it and tap it on the side of the trash can or dust receptacle.

CAUTION: Never operate this saw unless the dust bag or DeWALT dust extractor is in place. Wood dust may create a breathing hazard.

Basic Saw Cuts

If the slide feature is not used, ensure the saw head is pushed back as far as possible and the rail lock knob **24** is tightened. This will prevent the saw from sliding along its rails as the workpiece is engaged.

Cutting of multiple pieces is not recommended but can be done safely by ensuring that each piece is held firmly against the table and fence.

Straight Vertical Crosscut (Fig. A)

1. Set and lock the mitre arm at zero, and hold the wood firmly on the table and against the fence **16**.
2. With the rail lock knob **24** tightened, turn on the saw by squeezing the trigger switch **5**.
3. When the saw comes up to speed, lower the arm smoothly and slowly to cut through the wood. Let the blade come to a full stop before raising arm.

Sliding Crosscut (Fig. A, O)

When cutting anything larger than a 51 x 150 mm (51 x 105 mm at 45° mitre) workpiece, use an out-down-back motion with the rail lock knob **24** loosened.

1. Pull the saw out toward you.
2. Lower the saw head down toward the workpiece.
3. Slowly push the saw back to complete the cut.

Do not allow the saw to contact the top of the workpiece while pulling out. The saw may run toward you, possibly causing personal injury or damage to the workpiece.

Mitre Crosscut (Fig. P)

The mitre angle is often 45° for making corners, but can be set anywhere from zero to 50° left or 60° right. Proceed as for a straight vertical crosscut.

When performing a mitre cut on workpieces wider than 51 x 105 mm that are shorter in length, always place the longer side against the fence.

Bevel Cut (Fig. A, Y2)

Bevel angles can be set from 49° right to 49° left and can be cut with the mitre arm set between 50° left or 60° right. Refer to the **Features and Controls** section for detailed instructions on the bevel system.

1. Loosen the bevel lock knob **28**, and move the saw to the left or right as desired. It is necessary to move the fence **16** to allow clearance. Tighten the fence adjustment knob **63** after positioning the fences.
2. Tighten the bevel lock firmly.

At some extreme angles, the right or left side fence might have to be removed. Refer to **Fence Adjustment** in the **Adjustments** section for important information on adjusting the fences for certain bevel cuts.

To remove the left or right fence, unscrew the fence adjustment knob **63** several turns and slide the fence out.

Grooving (Fig. A)

Your saw is equipped with a grooving stop **35**, depth adjustment screw **34** and wing nut **33** to allow for groove cutting.

- Flip the grooving stop **35** towards the front of the saw.
- Adjust the wing nut **33** and depth adjustment screw **34** to set the depth of the groove cut.

Quality of Cut

The smoothness of any cut depends on a number of variables, such as the material being cut, blade type, blade sharpness and rate of cut.

When smoothest cuts are desired for molding and other precision work, a sharp (60 tooth carbide) blade and a slower, even cutting rate will produce the desired results.

WARNING: Ensure that the material does not move or creep while cutting; clamp it securely in place. Always let the blade come to a full stop before raising arm. If small fibers of wood still split out at the rear of the workpiece, stick a piece of masking tape on the wood where the cut will be made. Saw through the tape and carefully remove tape when finished.

Clamping the Workpiece

WARNING: A workpiece that is clamped, balanced and secure before a cut may become unbalanced after a cut is completed. An unbalanced load may tip the saw or anything the

saw is attached to, such as a table or workbench. When making a cut that may become unbalanced, properly support the workpiece and ensure the saw is firmly bolted to a stable surface. Personal injury may occur.

WARNING: The clamp foot must remain clamped above the base of the saw whenever the clamp is used. Always clamp the workpiece to the base of the saw – not to any other part of the work area. Ensure the clamp foot is not clamped on the edge of the base of the saw.

CAUTION: Always use a work clamp to maintain control and reduce the risk of personal injury and workpiece damage.

Use the material clamp provided with your saw. The left or right fence will slide from side to side to aid in clamping. Other aids such as spring clamps, bar clamps or C-clamps may be appropriate for certain sizes and shapes of material.

To Install Clamp

1. Insert it into the hole **29** behind the fence. The clamp should be facing toward the back of the mitre saw. The groove on the clamp rod should be fully inserted into the base. Ensure this groove is fully inserted into the base of the mitre saw. If the groove is visible, the clamp will not be secure.
2. Rotate the clamp 180° toward the front of the mitre saw.
3. Loosen the knob to adjust the clamp up or down, then use the fine adjust knob to firmly clamp the workpiece.

NOTE: Place the clamp on the opposite side of the base when beveling. ALWAYS MAKE DRY RUNS (UNPOWERED) BEFORE FINISH CUTS TO CHECK THE PATH OF THE BLADE. ENSURE THE CLAMP DOES NOT INTERFERE WITH THE ACTION OF THE SAW OR GUARDS.

Support for Long Pieces

ALWAYS SUPPORT LONG PIECES.

For best results, use the DE7023-XJ or DE7033-XJ leg stands to extend the table width of your saw. Support long workpieces using any convenient means such as sawhorses or similar devices to keep the ends from dropping.

Cutting Picture Frames, Shadow Boxes and Other Four-Sided Projects (Fig. R)

Try a few simple projects using scrap wood until you develop a “feel” for your saw. Your saw is the perfect tool for mitring corners like the one shown in Figure R.

Sketch 1 in Figure R shows a joint made with the bevel adjustment method. The joint shown can be made using either method.

- Using bevel adjustment:
 - The bevel for the two boards is adjusted to 45° each, producing a 90° corner.
 - The mitre arm is locked in the zero position and the bevel adjustment is locked at 45°.
 - The wood is positioned with the broad flat side against the table and the narrow edge against the fence.
- Using mitre adjustment:
 - The same cut can be made by mitring right and left with the broad surface against the fence.

Cutting Trim Molding and Other Frames (Fig. R)

Sketch 2 in Figure R shows a joint made by setting the mitre arm at 45° to mitre the two boards to form a 90° corner. To make this type of joint, set the bevel adjustment to zero and the mitre arm to 45°. Once again, position the wood with the broad flat side on the table and the narrow edge against the fence.

The two sketches in Figure R are for four-sided objects only. As the number of sides changes, so do the mitre and bevel angles. The chart below gives the proper angles for a variety of shapes, assuming that all sides are of equal length.

| Number of Sides | Mitre or Bevel Angle |
|-----------------|----------------------|
| 4 | 45° |
| 5 | 36° |
| 6 | 30° |
| 7 | 25.7° |
| 8 | 22.5° |
| 9 | 20° |
| 10 | 18° |

For a shape that is not shown in the chart, use the following formula: 180° divided by the number of sides equals the mitre (if the material is cut vertically) or bevel angle (if the material is cut laying flat).

Cutting Compound Mitres (Fig. Q, R, S, Z)

A compound mitre is a cut made using a mitre angle and a bevel angle at the same time. This is the type of cut used to make frames or boxes with slanting sides like the one shown in Figure Q.

WARNING: If the cutting angle varies from cut to cut, check that the bevel lock knob and the mitre lock handle are securely locked. These must be locked after making any changes in bevel or mitre.

WARNING: The saw must be fixed on a base support when performing compound cuts to prevent tip over. Refer to **Bench Mounting** and Fig. Z.

The chart shown below will assist you in selecting the proper bevel and mitre settings for common compound mitre cuts.

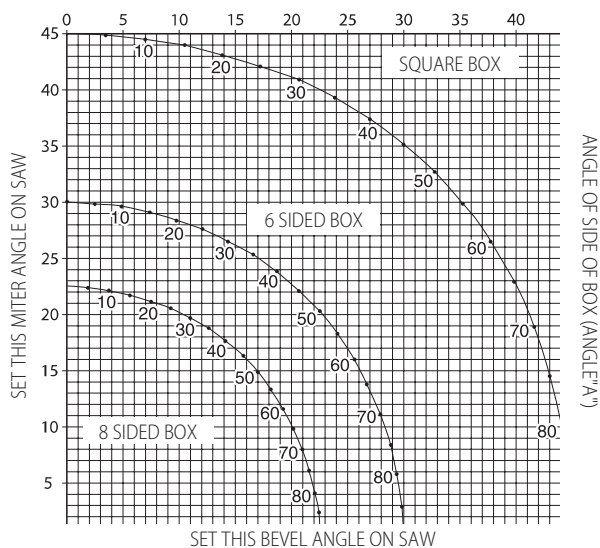

- Select the desired angle A (Fig. 5) of your project and locate that angle on the appropriate arc in the chart.
- From that point follow the chart straight down to find the correct bevel angle and straight across to find the correct mitre angle.
- Set your saw to the prescribed angles and make a few trial cuts. Practise fitting the cut pieces together.

Example: To make a 4-sided box with 26° exterior angles (Angle A, Fig. 5), use the upper right arc. Find 26° on the arc scale. Follow the horizontal intersecting line to either side to get mitre angle setting on saw (42°). Likewise, follow the vertical intersecting line to the top or bottom to get the bevel angle setting on the saw (18°). Always try cuts on a few scrap pieces of wood to verify the settings on the saw.

Cutting Base Moulding (Fig. J, T)

ALWAYS MAKE A DRY RUN WITHOUT POWER BEFORE MAKING ANY CUTS.

To complete straight 90° cuts, position the wood against the fence and hold it in place as shown in Figure T. Turn on the saw, allow the blade to reach full speed and lower the arm smoothly through the cut.

Cutting Base Molding from 76 mm to 171 mm High Vertically Against the Fence

NOTE: Use the slide lock lever 20, shown in Figure J, when cutting base molding measuring from 76 mm to 171 mm high vertically against the fence.

Position material as shown in Figure T.

| | Inside corner | Outside corner |
|------------|---|--|
| Left side | Mitre left 45° Save left side of cut | Mitre right 45° Save left side of cut |
| Right side | Mitre right 45° Save right side of cut | Mitre left 45° Save right side of cut |

Material up to 171 mm (6.75") can be cut as described above.

Cutting Crown Moulding (Fig. A, U1, U2)

Your mitre saw is well suited to the task of cutting crown moulding. In order to fit properly, crown moulding must be compound mitred with extreme accuracy.

Your mitre saw has special pre-set mitre latch points at 31.62° left and right for cutting crown moulding at the proper angle and bevel stop pawls at 33.86° left and right. There is also a mark on the bevel scale 17 at 33.9°. The chart below gives the proper settings for cutting crown moulding.

NOTE: Pretesting with scrap material is extremely important!

Instructions for Cutting Crown Moulding Laying Flat and Using the Compound Features (Fig. U1)

1. Moulding should lay flat with the broad back surface down on the saw table 60.
2. Place the top of the moulding against the fence 16.
3. The settings below are for 45° sprung crown moulding.

| | Inside corner | Outside corner |
|------------|--|--|
| Left side | Bevel left 30° Mitre table set at right 35.26° Save left end of cut | Bevel right 30° Mitre table set at left 35.26° Save left end of cut |
| Right side | Bevel right 30° Mitre table set at left 35.26° Save right end of cut | Bevel left 30° Mitre table set at right 35.26° Save right end of cut |

The settings below are for crown moulding with 52° angles at the top and 38° angles at the bottom.

| | Inside corner | Outside corner |
|------------|--|--|
| Left side | Bevel left 33.9° Mitre table set at right 31.62° Save left end of cut | Bevel right 33.9° Mitre table set at left 31.62° Save left end of cut |
| Right side | Bevel right 33.9° Mitre table set at left 31.62° Save right end of cut | Bevel left 33.9° Mitre table set at right 31.62° Save right end of cut |

Alternative Method for Cutting Crown Moulding

Cutting crown moulding using this method does not require a bevel cut. Minute changes in the mitre angle can be made without affecting the bevel angle. When corners other than 90° are encountered, the saw can be quickly and easily adjusted for them.

Instructions for Cutting Crown Moulding Angled Between the Fence and Base of the Saw for All Cuts (Fig. U2)

1. Angle the moulding so the bottom of the moulding (the part which goes against the wall when installed) is against the fence 16 and the top of the moulding is resting on the saw table 60.
2. The angled "flats" on the back of the moulding must rest squarely on the fence and saw table.

| | Inside corner | Outside corner |
|------------|--|---|
| Left side | Mitre right at 45° Save right side of cut | Mitre left at 45° Save right side of cut |
| Right side | Mitre left at 45° Save left side of cut | Mitre right at 45° Save left side of cut |

Special Cuts

WARNING: Never make any cut unless the material is secured on the table and against the fence.

Aluminum Cutting (Fig. V1, V2)

ALWAYS USE THE APPROPRIATE SAW BLADE MADE ESPECIALLY FOR CUTTING ALUMINUM.

Certain workpieces may require the use of a clamp or fixture to prevent movement during the cut. Position the material so that you will be cutting the thinnest cross section, as shown in Figure V1. Figure V2 illustrates the wrong way to cut these extrusions.

Use a stick wax cutting lubricant when cutting aluminum. Apply the stick wax directly to the saw blade 46 before cutting. Never apply stick wax to a moving blade. The wax provides proper lubrication and keeps chips from adhering to the blade.

Bowed Material (Fig. W1, W2)

When cutting bowed material always position it as shown in Figure W1 and never like that shown in Figure W2. Positioning the material incorrectly will cause it to pinch the blade.

Cutting Plastic Pipe or Other Round Material

Plastic pipe can be easily cut with your saw. It should be cut just like wood and **CLAMPED OR HELD FIRMLY TO THE FENCE TO KEEP IT FROM ROLLING.** This is extremely important when making angle cuts.

Cutting Large Material (Fig. X)

Occasionally you will encounter a piece of wood a little too large to fit beneath the lower guard. If this occurs, place your right thumb on the upper side of the guard 1 and roll the guard up just enough to clear the workpiece, as shown in Figure X. Avoid doing this as much as possible, but if need be, the saw will operate properly and make the bigger cut. NEVER TIE, TAPE, OR OTHERWISE HOLD THE GUARD OPEN WHEN OPERATING THIS SAW.

Special Set-up for Wide Crosscuts (Fig. Y1, Y2)

Your saw can cut very wide (up to 409 mm) workpieces when a special set-up is used. To set the saw up for these workpieces, follow these steps:

1. Remove both left and right sliding fences from the saw and set aside. To remove them, unscrew the fence adjustment knobs 63 several turns and slide each fence outward. Adjust and lock the mitre control so that it is at 0° mitre.
2. Make a platform using a piece of 38 mm thick particleboard or similar flat strong 38 mm thick wood to the dimensions: 368 x 660 mm. The platform must be flat, otherwise the material could move during cutting and cause injury.
3. Mount the 368 x 660 mm platform to the saw using four 76.2 mm long wood screws through the holes 62 in the base fence 61 (Fig. Y1). Four screws must be used to properly secure the material. When the special set-up is used, the platform will be cut into two pieces. Ensure the screws are tightened properly, otherwise material could loosen and cause injury. Ensure the platform is firmly flat on the table, against the fence, and centred evenly from left to right.

WARNING: Ensure the saw is mounted firmly to a stable flat surface. Failure to do so could cause the saw to be unstable and fall causing personal injury.

4. Place the workpiece to be cut on top of the platform mounted to the table. Ensure the workpiece is firmly against the back of the base fence 61 (Fig. Y2).
5. Secure the material before cutting. Cut slowly through the material using a out-down-and-back motion. Failure to clamp securely or cut slowly could result in the material coming loose and causing injury.

After several cuts are made at various mitre angles other than 0°, the platform may weaken and not properly support the work. Install a new, unused platform to the saw after presetting the desired mitre angle.

CAUTION: Continued use of a platform with several kerfs may cause loss of material control and possible injury.

MAINTENANCE

WARNING: To reduce the risk of serious personal injury, turn tool off and remove the battery packs or power supply before transporting, making any adjustments, cleaning, repairing, or removing/installing attachments or accessories. An accidental start-up can cause injury.

WARNING: To reduce the risk of serious personal injury, DO NOT touch the sharp points on the blade with fingers or hands while performing any maintenance.

DO NOT use lubricants or cleaners (particularly spray or aerosol) in the vicinity of the plastic guard. The polycarbonate material used in the guard is subject to attack by certain chemicals.



Lubrication

Your power tool requires no additional lubrication.



Cleaning

Before use, carefully check the upper guard, lower guard and dust duct to determine that they will operate properly. Ensure that chips, dust or workpiece particles do not block one of the functions.

In case of workpiece fragments jammed between the saw blade and guards, disconnect the machine from the power supply and follow the instructions given in **Changing or Installing a New Saw Blade**. Remove the jammed parts and reassemble the saw blade.

Periodically clean all dust and wood chips from around AND UNDER the base and the rotary table.

WARNING: Blow dirt and dust out of the main housing with dry air as often as dirt is seen collecting in and around the air vents. Wear approved eye protection and approved dust mask when performing this procedure.

WARNING: Never use solvents or other harsh chemicals for cleaning the non-metallic parts of the tool. These chemicals may weaken the plastic materials used in these parts. Use a cloth dampened only with water and mild soap. Never let any liquid get inside the tool; never immerse any part of the tool into a liquid.

Cleaning the DeWALT Corded Power Supply

WARNING: Never use solvents or other harsh chemicals for cleaning the non-metallic parts of the tool. These chemicals may weaken the plastic materials used in these parts. Use a cloth dampened only with water and mild soap. Never let any liquid get inside the tool; never immerse any part of the tool into a liquid.

Cleaning the Corded Power Supply Receptacle (Fig. D)

WARNING: Blow debris out of the corded power supply receptacle **37** with clean, dry air. To minimize the risk of eye injury, always wear eye protection and respiratory protection when performing this.

Dust Duct Cleaning

Depending on your cutting environment, saw dust can clog the dust duct and may prevent dust from flowing away from the cutting area properly. With the battery pack or corded power supply removed and the saw head raised fully, low pressure air or a large diameter dowel rod can be used to clear the dust out of the dust duct.

XPS™ LED Worklight Cleaning

For the best worklight performance, perform the following maintenance regularly with the battery or corded power supply removed.

- Carefully clean saw dust and debris from worklight lens with a cotton swab.
- DO NOT use solvents of any kind, they may damage the lens.
- Dust build-up can block the worklight and prevent it from accurately indicating the line of cut.
- Follow mitre saw's instruction manual to remove and install blade.
- With blade removed from saw, clean pitch and build-up from blade. Pitch and debris can interfere with the worklight and prevent it from accurately indicating the line of cut.

Optional Accessories

WARNING: Since accessories, other than those offered by DeWALT, have not been tested with this product, use of such accessories with this tool could be hazardous. To reduce the risk of injury, only DeWALT recommended accessories should be used with this product.

The following accessories, designed for your saw, may be helpful. In some cases, other locally obtained work supports, length stops, clamps, etc., may be more appropriate. Use care in selecting and using accessories.

Clamp: DE7082 (similar model included)

Used for firmly clamping workpiece to the saw table for precision cutting.

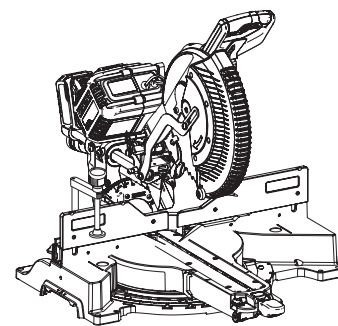

Dust Bag: DE7053 (included with some models)

Equipped with a zipper for easy emptying, the dust bag will capture the majority of the sawdust produced.



SAW BLADES: ALWAYS USE 305 mm SAW BLADES WITH 25.4 mm/30 mm ARBOUR HOLES. SPEED RATING MUST BE AT LEAST 4800 RPM. Never use a smaller diameter blade. It will not be guarded properly. Use crosscut blades only! Do not use blades designed for ripping, combination blades or blades with hook angles in excess of 7°.

| BLADE DESCRIPTIONS | | |
|--|----------|-------|
| APPLICATION | DIAMETER | TEETH |
| Construction Saw Blades (thin kerf with anti-stick rim) | | |
| General Purpose | 305 mm | 40 |
| Fine Crosscuts | 305 mm | 60 |
| Woodworking Saw Blades (provide smooth, clean cuts) | | |
| Fine crosscuts | 305 mm | 80 |
| Non-ferrous metals | 305 mm | 96 |

Consult your dealer for further information on the appropriate accessories.

Protecting the Environment



Separate collection. Products and batteries marked with this symbol must not be disposed of with normal household waste.

Products and batteries contain materials that can be recovered or recycled reducing the demand for raw materials. Please recycle electrical products and batteries according to local provisions. Further information is available at www.2helpU.com.

Rechargeable Battery Pack

This long life battery pack must be recharged when it fails to produce sufficient power on jobs which were easily done before. At the end of its technical life, discard it with due care for our environment:

- Run the battery pack down completely, then remove it from the tool.
- Li-Ion cells are recyclable. Take them to your dealer or a local recycling station. The collected battery packs will be recycled or disposed of properly.